

Panasonic®

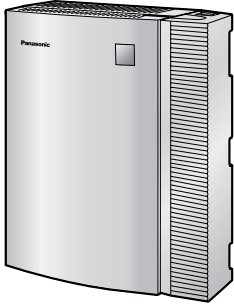

Advanced Hybrid System Installation Manual

Model No. **KX-TEA308**



Thank you for purchasing a Panasonic Advanced Hybrid System.
Please read this manual carefully before using this product and save this manual for future use.

KX-TEA308: Version 3.0

System Components

System Components Table

	Model	Description
Main Unit	KX-TEA308	Advanced Hybrid System: 3 Outside (CO) Lines, 8 Hybrid Extensions
Optional Service Cards	KX-TE82460	2-Port Doorphone Card
	KX-TE82492	2-Channel Voice Message Card
	KX-TE82494*1	3-Port Caller ID Card
Proprietary Equipment	KX-T30865	Doorphone
	KX-A227	Backup Battery Cable

*1 This card can only be used with a PBX that has software version 3.0 or later and hardware version 2 or later. The existing 3-Port Caller ID Card (KX-TE82493) can also be used, regardless of the PBX version.

Note

The hardware version of the PBX can be found on the label affixed to the side of the unit.

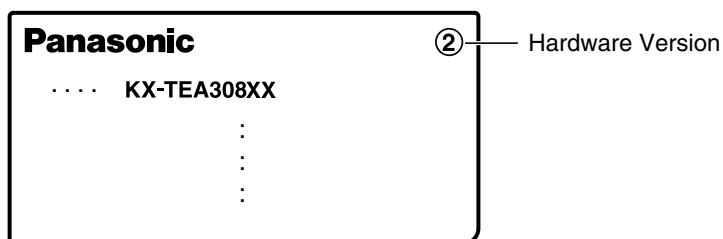

Abbreviations in this manual

- Proprietary Telephone: PT
- Single Line Telephone: SLT
- Direct Station Selection: DSS

Compatible Proprietary Telephones

- KX-T7700, KX-T7300, and KX-T7000 series PTs
- KX-T7710 SLT
- KX-T7740, KX-T7340, and KX-T7040 DSS Consoles

For the equipment that can be connected to the PBX, refer to "1.2.2 System Connection Diagram".

Notice

Certain models may not be available in your country/area.
 Certain PTs and features may not be available in your country/area. Consult your certified Panasonic dealer for more information.

Important Notice

Prior to connection of this product, please verify that the intended operating environment is supported.

Satisfactory performance cannot be guaranteed for the following:

- interoperability and compatibility with all devices and systems connected to this product
- proper operation and compatibility with services provided by telecommunications companies over connected networks

Important Safety Instructions

When using your telephone equipment, basic safety precautions should always be followed to reduce the risk of fire, electric shock and injury to persons, including the following:

1. Read and understand all instructions.
2. Follow all warnings and instructions marked on the product.
3. The product must only be installed and serviced by qualified service personnel. The product should be used as-is from the time of purchase; it should not be disassembled or modified. Disassembly or modification can cause a fire, electric shock, or damage to the product.
4. Unplug the product from the wall outlet before cleaning. Do not use liquid cleaners or aerosol cleaners. Clean with a damp cloth.
5. Do not use this product near water, for example, near a bathtub, wash bowl, kitchen sink, or laundry tub, in a wet basement, or near a swimming pool.
6. Do not place the product on an unstable surface, as a fall may cause serious internal damage.
7. Slots and openings in the front, back and bottom of the cabinet are provided for ventilation; to protect it from overheating, these openings must not be blocked or covered. The openings should never be blocked by placing the product on a bed, sofa, rug, or other similar surface while in use. The product should never be placed near or over a radiator or other heat source. This product should not be placed in a sealed environment unless proper ventilation is provided.
8. The product should only be connected to the type of electrical power supply specified on the product label. If you are not sure of the type of power supply to your home, consult your dealer or local power company.
9. For safety purposes this unit is equipped with an earthed plug. If you do not have an earthed outlet, please have one installed. Do not bypass this safety feature by tampering with the plug.
10. Do not allow anything to rest on the power cord. Do not locate this product where the power cord may be stepped on or tripped on.
11. To reduce the risk of fire or electric shock, do not overload wall outlets and extension cords.
12. Do not insert objects of any kind into this product through its slots and openings, as they may touch dangerous voltage points or short out parts that could result in a risk of fire or electric shock. Never spill liquid of any kind on or in the product.
13. Opening or removing covers may expose you to dangerous voltages or other risks. Incorrect reassembly can cause electric shock.
14. Unplug this product from the wall outlet and have it serviced by qualified service personnel in the following cases:
 - a) When the power supply cord or plug is damaged or frayed.
 - b) If liquid has been spilled into the product.
 - c) If the product has been exposed to rain or water.
 - d) If the product does not operate according to the operating instructions. Adjust only the controls that are explained in the operating instructions. Improper adjustment of other controls may result in damage and may require service by a qualified technician to restore the product to normal operation.
 - e) If the product has been dropped or the cabinet has been damaged.
 - f) If product performance deteriorates.
15. Avoid using wired telephones during an electrical storm. There is a remote risk of electric shock from lightning.
16. Do not use a telephone in the vicinity of a gas leak to report the leak.

SAVE THESE INSTRUCTIONS

Precautions

- Keep the unit away from heating appliances and devices that generate electrical noise such as fluorescent lamps, motors and televisions. These noise sources can interfere with the performance of the PBX.
- This unit should be kept free of dust, moisture, high temperature (more than 40 °C) and vibration, and should not be exposed to direct sunlight.
- If you are having problems making calls to outside destinations, follow this procedure to test the outside (CO) lines:
 1. Disconnect the PBX from all outside (CO) lines.
 2. Connect known working single line telephones (SLTs) to those outside (CO) lines.
 3. Make a call to an external destination using those SLTs.If a call cannot be carried out correctly, there may be a problem with the outside (CO) line that the SLT is connected to. Contact your telephone company.
If all SLTs operate properly, there may be a problem with your PBX. Do not reconnect the PBX to the outside (CO) lines until it has been serviced by an authorised Panasonic Factory Service Centre.
- Wipe the unit with a soft cloth. Do not clean the unit with abrasive powders or with chemical agents such as benzene or thinner.

Information on Disposal for Users of Waste Electrical & Electronic Equipment (private households)

- This symbol on the products and/or accompanying documents means that used electrical and electronic products should not be mixed with general household waste. For proper treatment, recovery and recycling, please take these products to designated collection points, where they will be accepted on a free of charge basis. Alternatively, in some countries you may be able to return your products to your local retailer upon the purchase of an equivalent new product. Disposing of this product correctly will help to save valuable resources and prevent any potential negative effects on human health and the environment which could otherwise arise from inappropriate waste handling. Please contact your local authority for further details of your nearest designated collection point. Penalties may be applicable for incorrect disposal of this waste, in accordance with national legislation.

For business users in the European Union

- If you wish to discard electrical and electronic equipment, please contact your dealer or supplier for further information.

Information on Disposal in other Countries outside the European Union

- This symbol is only valid in the European Union. If you wish to discard this product, please contact your local authorities or dealer and ask for the correct method of disposal.



For users in Finland, Norway and Sweden only

- This unit may only be installed in a room or space with restricted access, and equipotential bonding must be applied. For information on earthing, refer to "2.2.5 Connecting Frame Earth".

For users in New Zealand only

- This equipment shall not be set to make automatic calls to the Telecom '111' Emergency Service.
- The grant of a Telepermit for any item of terminal equipment indicates only that Telecom has accepted that the item complies with minimum conditions for connection to its network. It indicates no endorsement of the product by Telecom, nor does it provide any sort of warranty. Above all, it provides no assurance that any item will work correctly in all respects with another item of Telepermitted equipment of a different make or model, nor does it imply that any product is compatible with all of Telecom's network services.
- This equipment is not capable, under all operating conditions, of correct operation at the higher speeds for which it is designed. Telecom will accept no responsibility should difficulties arise in such circumstances.
- Some parameters required for compliance with Telecom's Telepermit requirements are dependent on the equipment (PBX) associated with this modem. In order to operate within the limits for compliance with Telecom's Specifications, the associated PBX equipment shall be set to ensure that modem calls are answered between 3 and 30 seconds of receipt of ringing.
- **IMPORTANT NOTICE**
Under power failure conditions, the connected telephones may not operate. Please ensure that a separate telephone, not dependent on local power, is available for emergency use.
- **APPLICABLE ONLY TO TELECOM CUSTOMERS WHO HAVE AUTOMATIC ACCESS TO OTHER CARRIERS FOR TOLL CALLS**
When calling back a number from the Caller ID list, all numbers prefixed with "0 + AREA CODE" will be automatically forwarded to your toll carrier. This includes numbers in your local calling area. The zero + area code should either be removed when calling back local numbers, or check with your toll carrier that a charge will not be levied.
- All persons using this device for recording telephone conversations shall comply with New Zealand law. This requires that at least one party to the conversation is to be aware that it is being recorded. In addition, the principles enumerated in the Privacy Act 1993 shall be complied with in respect to the nature of the personal information collected, the purpose for its collection, how it is used, and what is disclosed to any other party.

For users in Taiwan only

- Lithium batteries can be found in the circuit boards of the main board and optional cards of the PBX.

Notes

- When disposing of any of the above products, all batteries must be removed. Follow the applicable laws, regulations, and guidelines in your country/area regarding disposal of batteries.
- When replacing a battery, use only the same battery type, or an equivalent recommended by the battery manufacturer.

Notice

Regarding removing or replacing a battery in the circuit board, consult your dealer.



廢電池請回收

WARNING

- **THIS UNIT MAY ONLY BE INSTALLED AND SERVICED BY QUALIFIED SERVICE PERSONNEL.**
- **IF DAMAGE TO THE UNIT EXPOSES ANY INTERNAL PARTS, DISCONNECT THE POWER SUPPLY CORD IMMEDIATELY AND RETURN THE UNIT TO YOUR DEALER.**
- **UNPLUG THIS UNIT FROM THE AC OUTLET IF IT EMITS SMOKE, AN ABNORMAL SMELL OR MAKES UNUSUAL NOISE. THESE CONDITIONS CAN CAUSE FIRE OR ELECTRIC SHOCK. CONFIRM THAT SMOKE HAS STOPPED AND CONTACT AN AUTHORISED PANASONIC FACTORY SERVICE CENTRE.**
- **WHEN RELOCATING THE EQUIPMENT, FIRST DISCONNECT THE TELECOM CONNECTION BEFORE DISCONNECTING THE POWER CONNECTION. WHEN THE UNIT IS INSTALLED IN THE NEW LOCATION, RECONNECT THE POWER FIRST, AND THEN RECONNECT THE TELECOM CONNECTION.**
- **TO PREVENT POSSIBLE FIRE OR ELECTRIC SHOCK, DO NOT EXPOSE THIS PRODUCT TO RAIN OR MOISTURE.**
- **THE POWER SUPPLY CORD IS USED AS THE MAIN DISCONNECT DEVICE. ENSURE THAT THE AC OUTLET IS LOCATED NEAR THE EQUIPMENT AND IS EASILY ACCESSIBLE.**

CAUTION

DANGER OF EXPLOSION EXISTS IF A BATTERY IS INCORRECTLY REPLACED. REPLACE ONLY WITH THE SAME OR EQUIVALENT TYPE RECOMMENDED BY THE BATTERY MANUFACTURER. DISPOSE OF USED BATTERIES ACCORDING TO THE MANUFACTURER'S INSTRUCTIONS.

For Future Reference

Please print, record, and retain the following information for future reference.

Note

The serial number of this product can be found on the label affixed to the unit. You should record the model number and the serial number of this unit as a permanent record of your purchase to aid in identification in the event of theft.

MODEL NO.	_____
SERIAL NO.	_____
DATE OF PURCHASE	_____
NAME OF DEALER	_____
DEALER'S ADDRESS	_____ _____ _____ _____
DEALER'S TEL. NO.	_____

CE The KX-TEA308E, the KX-TEA308NE, the KX-TEA308GR, the KX-TEA308CE, and the KX-TEA308PD are designed to interwork with the Analogue Public Switched Telephone Network (PSTN) of European countries.

Panasonic System Networks Co., Ltd./Panasonic System Networks Company U.K. Ltd. declares that this equipment is in compliance with the essential requirements and other relevant provisions of Radio & Telecommunications Terminal Equipment (R&TTE) Directive 1999/5/EC.

Declarations of Conformity for the relevant Panasonic products described in this manual are available for download by visiting:

<http://www.doc.panasonic.de>

Contact to Authorised Representative:
Panasonic Testing Centre
Panasonic Marketing Europe GmbH
Winsbergring 15, 22525 Hamburg, Germany

Introduction

About the Installation Manual

This Installation Manual is designed to serve as an overall technical reference for Panasonic Advanced Hybrid System, KX-TEA308. It explains how to install the hardware and programme this PBX using KX-TEA308 Maintenance Console.

The Installation Manual is divided into the following sections:

Section 1 System Outline

Provides general information on the PBX, including the system capacity and specifications.

Section 2 Installation

Provides detailed instructions for installing the PBX, optional service cards, and peripheral equipment.

Section 3 Guide for KX-TEA308 Maintenance Console

Explains how to install and use KX-TEA308 Maintenance Console, a PC-based programming utility.

Section 4 Troubleshooting

Provides information on troubleshooting and restarting the PBX.

About the Other Manuals

The following manuals are also available:

Feature Guide

Explains what the PBX can do, as well as how to obtain the most of its many features and facilities.

User Manual

Describes how users can access commonly used features and functions with proprietary telephones (PTs), single line telephones (SLTs), and Direct Station Selection (DSS) Consoles.



Trademarks

- Microsoft and Windows are either registered trademarks or trademarks of Microsoft Corporation in the United States and/or other countries.
- Intel and Celeron are trademarks or registered trademarks of Intel Corporation or its subsidiaries in the United States and other countries.
- All other trademarks identified herein are the property of their respective owners.
- Screen shots reprinted with permission from Microsoft Corporation.

Precautions for Users in the United Kingdom

FOR YOUR SAFETY, PLEASE READ THE FOLLOWING TEXT CAREFULLY.

This appliance is supplied with a moulded three-pin mains plug for your safety and convenience. A 5 amp fuse is fitted in this plug. Should the fuse need to be replaced, please ensure that the replacement fuse has a rating of 5 amps and that it is approved by ASTA or BSI to BS1362.

Check for the ASTA mark  or the BSI mark  on the body of the fuse.

If the plug contains a removable fuse cover, you must ensure that it is refitted when the fuse is replaced. If you lose the fuse cover, the plug must not be used until a replacement cover is obtained. A replacement fuse cover can be purchased from your local Panasonic dealer.

IF THE FITTED MOULDED PLUG IS UNSUITABLE FOR THE AC OUTLET IN YOUR PREMISES, THEN THE FUSE SHOULD BE REMOVED AND THE PLUG CUT OFF AND DISPOSED OF SAFELY. THERE IS A DANGER OF SEVERE ELECTRICAL SHOCK IF THE CUT-OFF PLUG IS INSERTED INTO ANY 13 AMP OUTLET.

If a new plug is to be fitted, please observe the wiring code as shown below. If in any doubt, please consult a qualified electrician.

WARNING

THIS APPLIANCE MUST BE EARTHED.

IMPORTANT: The wires in the mains lead are coloured as follows:

Green-and-yellow: Earth

Blue: Neutral

Brown: Live

As the colours of the wires in the mains lead of this apparatus may not correspond with the coloured markings identifying the terminals in your plug, proceed as follows.

The wire that is coloured GREEN-AND-YELLOW must be connected to the terminal in the plug that is marked with the letter E or by the safety earth symbol  or coloured GREEN or GREEN-AND-YELLOW.

The wire that is coloured BLUE must be connected to the terminal that is marked with the letter N or coloured BLACK.

The wire that is coloured BROWN must be connected to the terminal that is marked with the letter L or coloured RED.

How to replace the fuse: Open the fuse compartment with a screwdriver and replace the fuse and fuse cover.

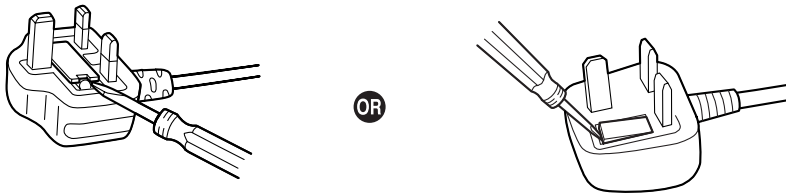

The equipment must be connected to direct extension lines, and a payphone should not be connected as an extension.

999 and 112 can be dialled on the apparatus after accessing the Exchange line for the purpose of making outgoing calls to the BT emergency services.

During dialling, this apparatus may tinkle the bells of other telephones using the same line. This is not a fault and we advise you not to call Fault Repair Service.

Table of Contents

1	System Outline	15
1.1	System Highlights	16
1.1.1	System Highlights	16
1.2	Basic System Construction	17
1.2.1	Main Unit	17
1.2.2	System Connection Diagram	18
1.3	Specifications	19
1.3.1	General Description	19
1.3.2	Characteristics	20
1.3.3	System Capacity	21
2	Installation	23
2.1	Before Installing	24
2.1.1	Before Installing	24
2.2	Installing the Advanced Hybrid System	26
2.2.1	Unpacking	26
2.2.2	Names and Locations	27
2.2.3	Opening/Closing Covers	28
2.2.4	Securing the Cables	31
2.2.5	Connecting Frame Earth	33
2.2.6	Connecting Backup Batteries	34
2.2.7	Wall Mounting	36
2.2.8	Installing Surge Protector	39
2.3	Installing Optional Service Cards	42
2.3.1	Location of Optional Service Cards	42
2.3.2	3-Port Caller ID Card (KX-TE82494)	43
2.3.3	2-Port Doorphone Card (KX-TE82460)	45
2.3.4	2-Channel Voice Message Card (KX-TE82492)	46
2.4	Connecting Outside (CO) Lines	48
2.4.1	Connecting Outside (CO) Lines	48
2.5	Connecting Extensions	49
2.5.1	Connecting Extensions	49
2.5.2	Connecting Extensions in Parallel	51
2.6	Connecting Doorphones and Door Openers	52
2.6.1	Connecting Doorphones and Door Openers	52
2.7	Connecting Doorbell or Door Chime	56
2.7.1	Connecting Doorbell or Door Chime	56
2.8	Connecting Peripherals	57
2.8.1	Connecting Peripherals	57
2.9	Power Failure Connections	61
2.9.1	Power Failure Connections	61
2.10	Starting the Advanced Hybrid System	62
2.10.1	Starting the Advanced Hybrid System	62
3	Guide for KX-TEA308 Maintenance Console	65
3.1	Installing KX-TEA308 Maintenance Console	66
3.1.1	Installing KX-TEA308 Maintenance Console on a PC	66
3.2	Connection	68

3.2.1	Connection	68
3.2.2	Starting KX-TEA308 Maintenance Console for the first time	71
3.2.3	Accessing PBX via Internal Modem	72
4	Troubleshooting	75
4.1	Troubleshooting	76
4.1.1	Installation	76
4.1.2	Connection	77
4.1.3	Operation.....	78
4.1.4	System Restart.....	79
4.1.5	System Reset with System Data Clear	80
5	Appendix.....	81
5.1	Revision History	82
5.1.1	Version 2.0.....	82
5.1.2	Version 3.0.....	82
Index	83

Section 1

System Outline

This section provides general information on the PBX, including the system capacity and specifications.

1.1 System Highlights

1.1.1 System Highlights

Built-in Voice Message (BV) (Optional voice message card required)

Built-in Voice Message (BV) allows a caller to leave a voice message in a user's personal message area or the PBX's common message area.

Fixed Line SMS Terminal Support (Optional Caller ID card required)

The PBX can relay incoming calls from a Short Message Service (SMS) centre to specific single line telephones (SLTs) that support SMS. Fixed Line SMS is a service that allows text messages to be sent and received via Public Switched Telephone Network (PSTN) access. We recommend using SMS-enabled Panasonic SLTs.

Caller ID Display on SLT (Optional Caller ID card required)

The PBX can receive Caller ID information (telephone numbers and callers' names) from calls received on outside (CO) lines. This information can be shown on the displays of SLTs that support Caller ID as well as proprietary telephones (PTs) when receiving calls.

3-level Automated Attendant (AA)

3-level Automated Attendant (AA) service allows a caller to dial a single-digit number (Direct Inward System Access [DISA] AA number) following the guidance of 3-level DISA outgoing messages (OGMs), and be connected to the desired party automatically.

Call Charge Calculation

The PBX can automatically calculate the approximate cost of calls and limit telephone usage to a preprogrammed budget on each extension. This feature allows users to calculate the cost of a call based on time, the leading digits of a phone number and/or the outside (CO) line carrying the call.

PC Programming

System programming settings can be accessed using a PC and the Panasonic KX-TEA308 Maintenance Console software as well as by using a PT.

The PBX software can be upgraded via the Serial Interface (RS-232C) port or USB port, using the KX-TEA308 Maintenance Console software.

Quick Setup

Basic PBX parameters such as Automatic Configuration for Outside (CO) Line Type, Country Setting can be programmed the first time the PBX is accessed with a PC using the KX-TEA308 Maintenance Console software.

Advanced Hybrid System

This PBX supports the connection of PTs, Direct Station Selection (DSS) Consoles and single line devices such as SLTs, fax machines, wireless telephones and data terminals.

1.2 Basic System Construction

1.2.1 Main Unit

The KX-TEA308 has a capacity of 3 outside (CO) lines and 8 extensions. It is capable of supporting Panasonic proprietary telephones (PTs), and single line devices such as single line telephones (SLTs), fax machines and data terminals.

To expand its capabilities, the PBX can be equipped with optional components or user-supplied peripherals, such as door openers, external speakers, and an external audio source such as a radio or CD player.

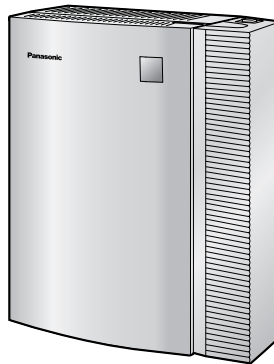

1.2.2 System Connection Diagram

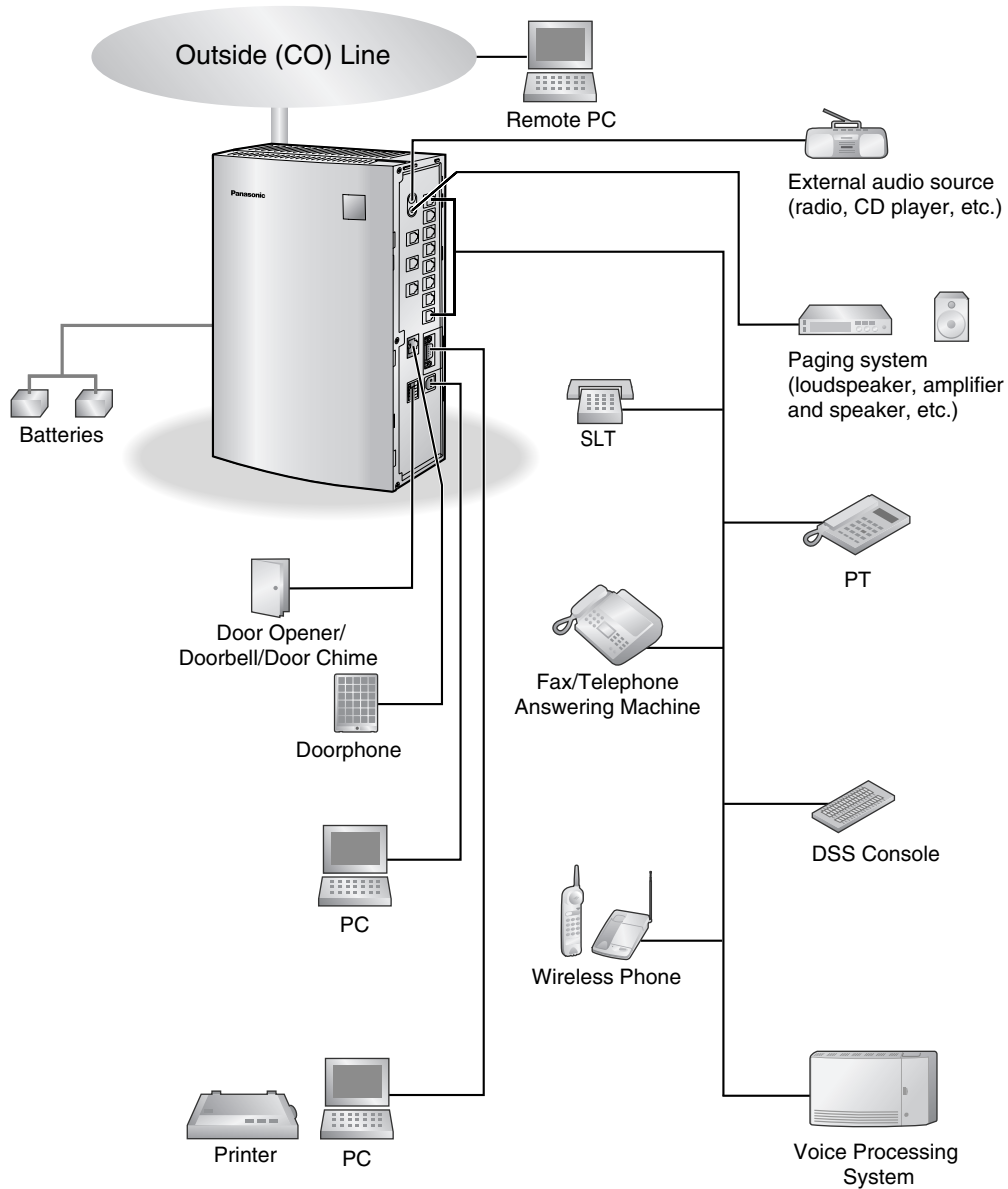

- Connect a display-equipped proprietary telephone (PT) to extension jack 01, as this extension is automatically designated as the manager extension.
- A PT and a single line telephone (SLT) can be connected in parallel to a Hybrid Port. (→ 2.5.2 Connecting Extensions in Parallel)

1.3 Specifications

1.3.1 General Description

Control Bus		Original bus (16-bit, 24 MHz)	
Switching		Space Division CMOS Crosspoint Switch	
Power Input		100 V AC to 240 V AC, 0.8 A to 0.4 A, 50 Hz/60 Hz	
External Battery		+24 V DC (+12 V DC × 2)	
Maximum Power Failure Tolerance		300 ms (without using backup batteries)	
Memory Backup Duration		7 years	
Dialling	Outside (CO) Line	Pulse (10 pps, 20 pps) or Tone (DTMF)	
	Extension	Pulse (10 pps, 20 pps) or Tone (DTMF)	
Intercom Path		3	
Mode Conversion		Pulse-DTMF	
Ring Frequency		20 Hz/25 Hz (selectable)	
Operating Environment	Temperature	0 °C to 40 °C	
	Humidity	10 % to 90 % (non-condensing)	
Conference Call Outside (CO) Line		2	
Music on Hold (MOH)		1 port Selectable MOH: Internal/External/Tone	
Paging	Internal	1	
	External	1 port	
Serial Interface Port	RS-232C	1	
	USB 1.1	1	
Extension Connection Cable		SLT	1-pair wire (T, R)
		PT	2-pair wire (T, R, H, L)
		DSS Console	1-pair wire (H, L)
Dimensions		249 mm (W) × 316 mm (H) × 73 mm (D)	
Weight (when fully expanded)		Approx. 1.8 kg	

1.3.2 Characteristics

Terminal Equipment Loop Limit	PT	40 Ω
	SLT	600 Ω including set
	Doorphone	20 Ω
Minimum Leakage Resistance	15 000 Ω minimum	
Maximum Number of Extension Instruments per Line	1 PT or SLT in standard connection 1 PT and 1 SLT in parallel connection	
Ring Voltage	65 Vrms at 20 Hz/25 Hz depending on the ringing load	
Outside (CO) Line Loop Limit	1600 Ω maximum	
Hookswitch Flash/Recall Timing Range	24 ms–2032 ms	
Door Opener Current Limit	30 V DC/30 V AC, 3 A maximum	
Paging Terminal Impedance	600 Ω	
MOH Terminal Impedance	10 000 Ω	

1.3.3 System Capacity

System Capacity

		KX-TEA308
Basic System	Outside (CO) lines	3
	Extensions for PT/SLT	8

Maximum Cards and Terminal Equipment

Item	KX-TEA308
PT	8
SLT	8
2-Port Doorphone Card	1
3-Port Caller ID Card	1
2-Channel Voice Message Card	1
Doorphone	2
Door Opener	2
Pager	1
Music on Hold (MOH)	1
DSS Console	2

System Data

Item	Max. Quantity
Operator	1
System Speed Dialling	100
One-touch Dialling	24 per extension (PT)
Personal Speed Dialling	10 per extension
Call Park Area	10
Absent Message	6
Toll Restriction (TRS) COS	5
Extension Group	8
Message Waiting	8 per extension
Message for Built-in Voice Message	125 messages (total 60 minutes)

1.3 Specifications

Section 2

Installation

This section provides detailed instructions for installing the PBX, optional service cards, and peripheral equipment.

2.1 Before Installing

2.1.1 Before Installing

Please read the following notes concerning installation and connection before installing the PBX and terminal equipment.

Be sure to comply with all applicable laws, regulations, and guidelines.

Safety Installation Instructions

When installing telephone wiring, basic safety precautions should always be followed to reduce the risk of fire, electric shock and injury to persons, including the following:

1. Never install telephone wiring during a lightning storm.
2. Never install telephone jacks in wet locations unless the jack is specifically designed for wet locations.
3. Never touch uninsulated telephone wires or terminals unless the telephone line has been disconnected at the network interface.
4. Use caution when installing or modifying telephone lines.

Installation Precautions

This PBX is designed for wall mounting only, and should be installed in a location where it is accessible for inspections and maintenance.

To prevent malfunction, noise, or discolouration, avoid installing the PBX in the following locations:

1. In direct sunlight and hot, cold, or humid places. (Temperature range: 0 °C to 40 °C)
2. Areas where sulfuric gases may be present, such as near thermal springs.
3. Areas where shocks or vibrations are frequent or strong.
4. High-dust areas, or places the PBX may come into contact with water or oil.
5. Near devices that generate high frequencies, such as sewing machines or electric welders.
6. On or near computers, telexes, or other office equipment, as well as microwave ovens or air conditioners. (It is preferable not to install the PBX in the same room as the above equipment.)
7. Within 1.8 m of radios and televisions. (Both the PBX and Panasonic proprietary telephones [PTs] should be at least 1.8 m away from such devices.)
8. Locations where other objects will obstruct the area around the PBX. Be especially careful to leave at least 20 cm of space above and 10 cm to the sides of the PBX for ventilation.

Wiring Precautions

Be sure to follow these instructions when wiring the unit:

1. Do not run unshielded telephone cables near AC power cables, computer cables, AC power sources, etc. When running cables near other noise-generating devices or cables, use shielded telephone cables or shield the telephone cables with metal tubing.
2. If cables are run on the floor, use protectors to prevent the cables from being stepped on. Avoid running cables under carpets.
3. Avoid using the same AC outlet for computers, telexes, and other office equipment, as noise generated by such equipment may hamper system performance or interrupt the system.

4. Use 2-pair telephone cables when connecting Panasonic PTs.
Use 1-pair telephone cables when connecting single line telephones (SLTs), data terminals, answering machines, computers, voice processing systems, etc.
5. Unplug the PBX from its power source when wiring, and plug the PBX back in only after all wiring is completed.
6. Mis-wiring may cause the PBX to operate improperly. Refer to Section 2, "Installation" when wiring the PBX.
7. If an extension does not operate properly, disconnect the telephone from the extension line and connect it again, or turn off the PBX using the power switch then turn it on again.
8. For safety purposes this unit is equipped with an earthed plug. If you do not have an earthed outlet, please have one installed. Do not bypass this safety feature by tampering with the plug.
9. Use twisted pair cable for outside (CO) line connection.
10. Outside (CO) lines should be installed with surge protectors. For details, refer to "2.4.1 Connecting Outside (CO) Lines", "2.2.8 Installing Surge Protector".

WARNING

Static-sensitive devices are used in this PBX. To protect printed circuit boards from static electricity, do not touch the connectors indicated below. To discharge static electricity from your body, touch ground or wear an earthing strap.

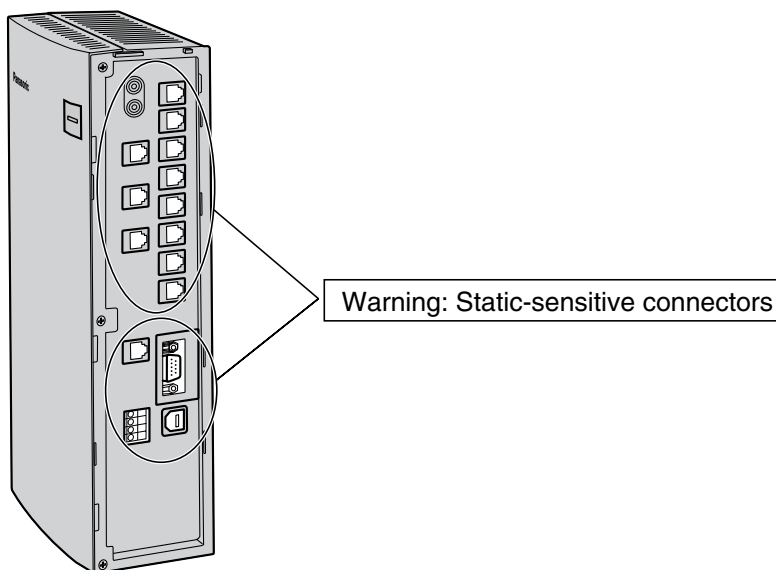

2.2 Installing the Advanced Hybrid System

2.2.1 Unpacking

The following items are included upon shipment.

Main Unit	1
AC Cord*	1*
CD-ROM, Documentation	1 set
Screw (Wall Mounting)	3
Washer (Wall Mounting)	3
Strap	1

* The type of the AC cord may vary depending on the country/area of use.
More than one type of AC cord may be included for countries/areas in Central and South America.

2.2.2 Names and Locations

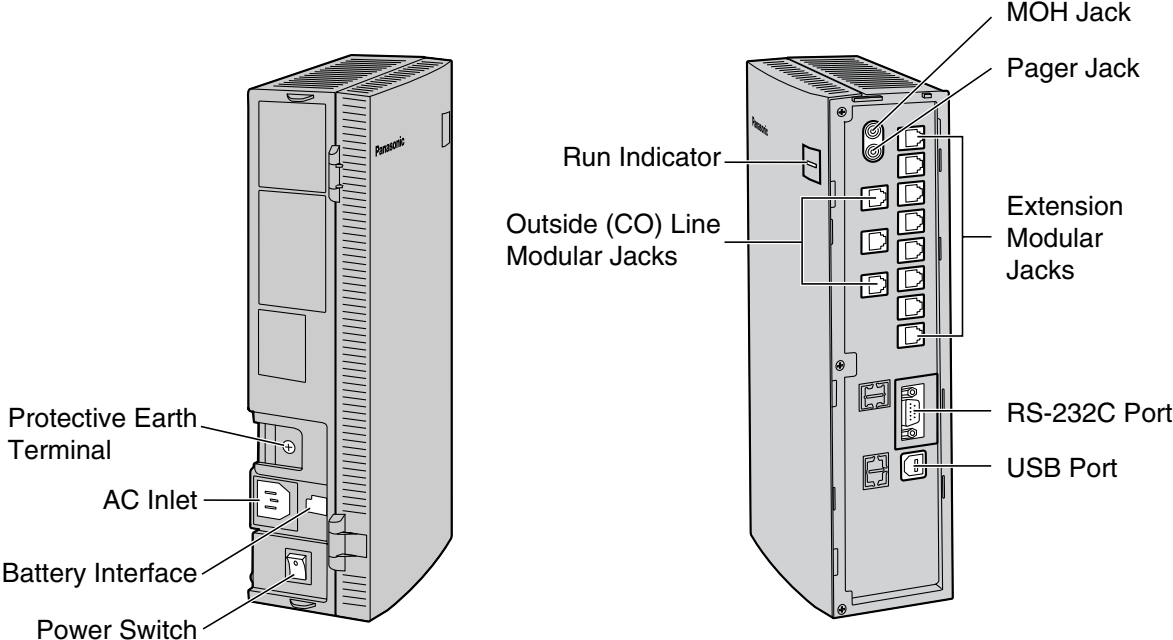

2.2.3 Opening/Closing Covers

Opening Covers

1. Pull the slide button to the right and, holding it, slide the cable cover upwards. Then turn the cable cover slightly to remove it.

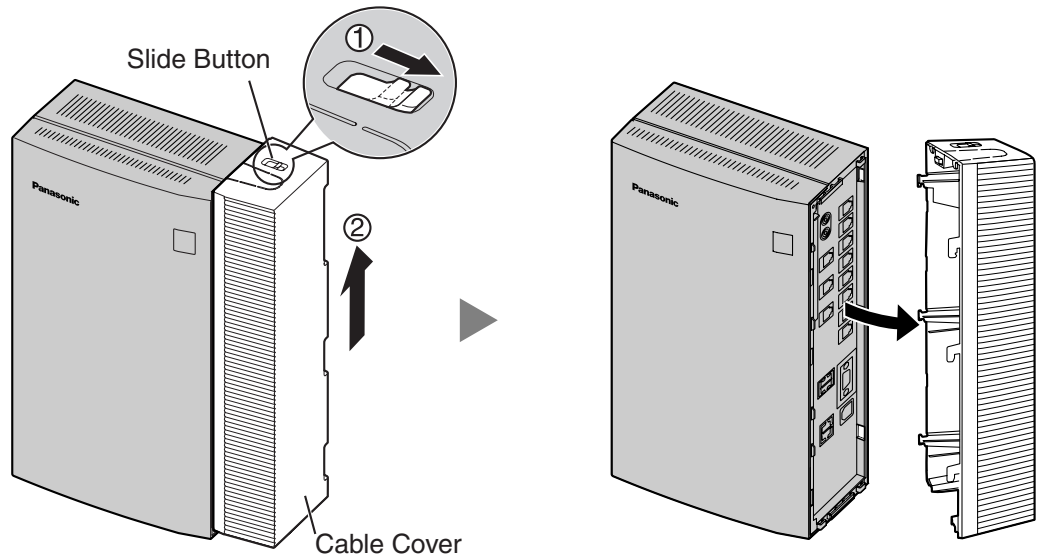

2. Remove the 3 cover screws.

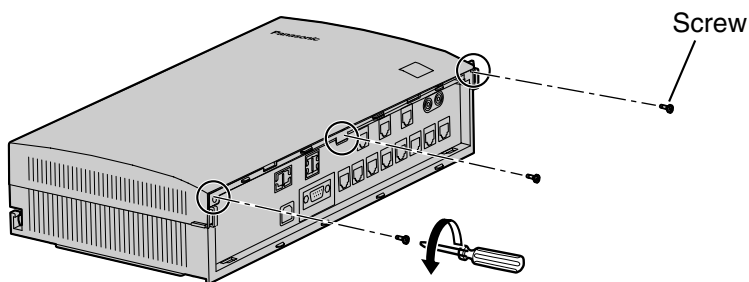

3. Holding the protrusions on both sides of the front cover, swing the cover open.

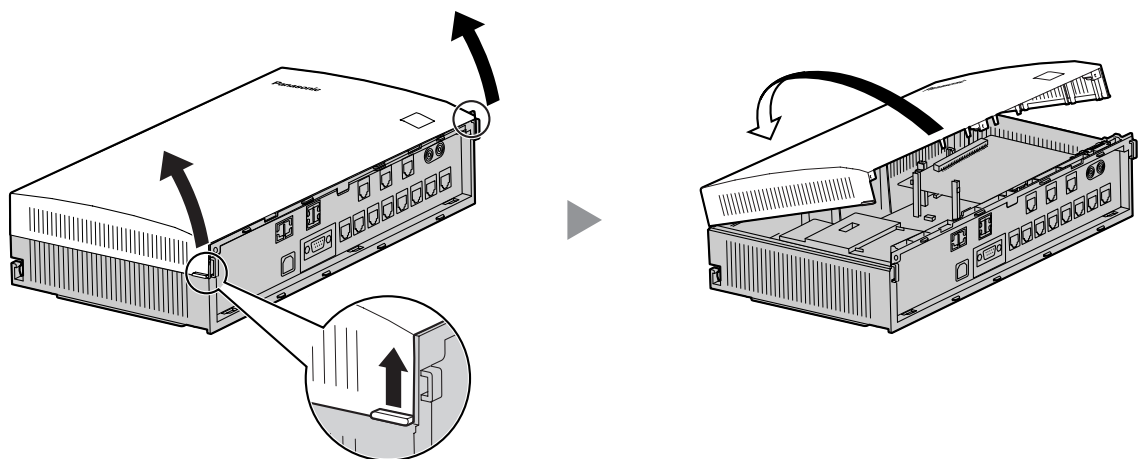

Removing/Attaching the Front Cover

If you prefer, you can remove the front cover.

Removing the Front Cover

Holding the front cover open at about a 45° angle, remove the front cover by pushing it in the direction of the arrow as shown below.

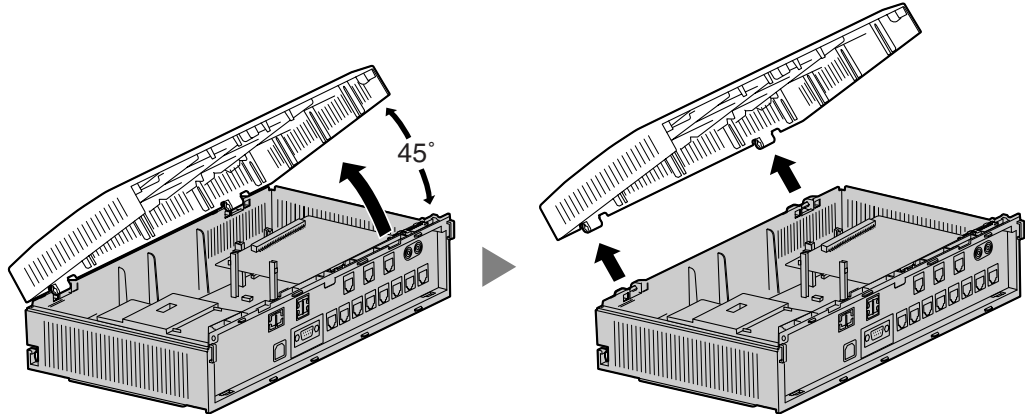

Attaching the Front Cover

Fit the front cover to the main unit as shown below, and then close the front cover.

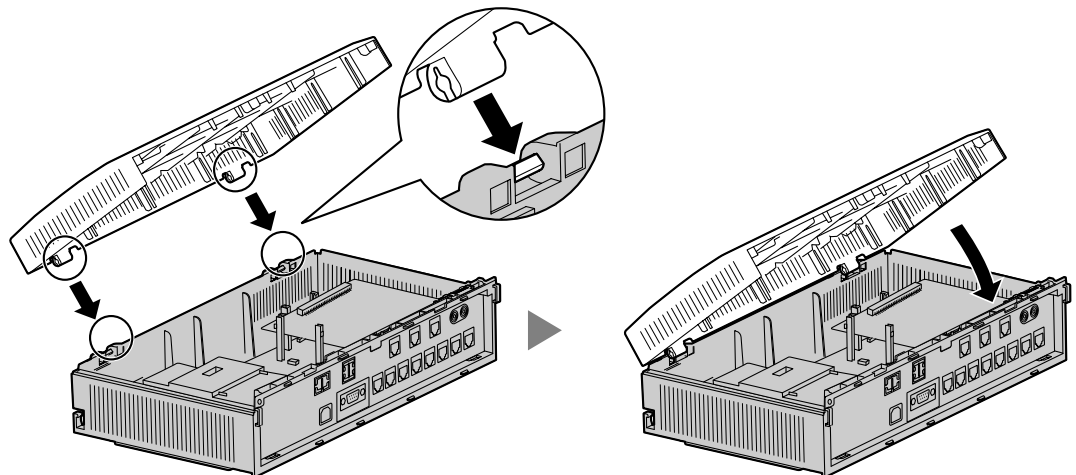

Closing Covers

1. Close the front cover, then tighten the 3 cover screws.

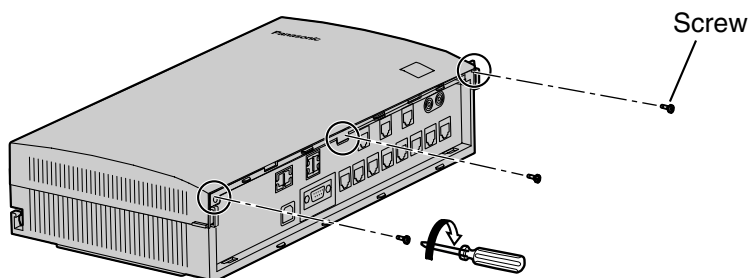

2.2 Installing the Advanced Hybrid System

2. Attach the rear hooks on the cable cover to the main unit, then swing the cable cover closed so that the front hooks fit in place.

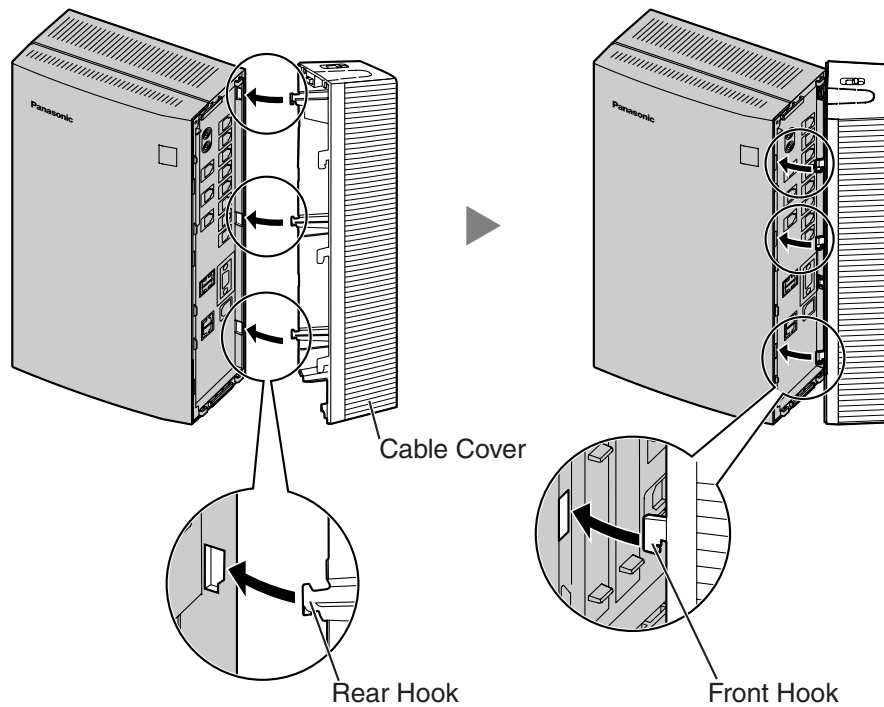

3. Slide the cable cover down until it locks.

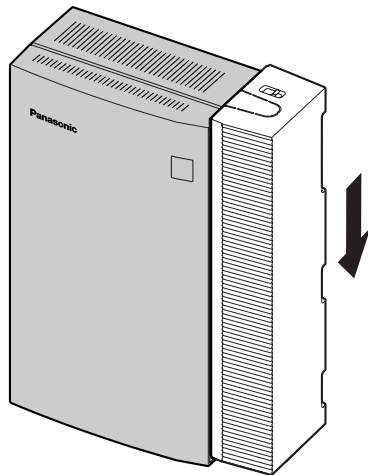

Note

For safety reasons, keep the front cover closed while the PBX is in operation.

CAUTION

Tighten the above screws firmly to prevent the main unit from falling when the PBX is carried.

2.2.4 Securing the Cables

1. Attach the included strap to either of the 2 rails depending on your preference.

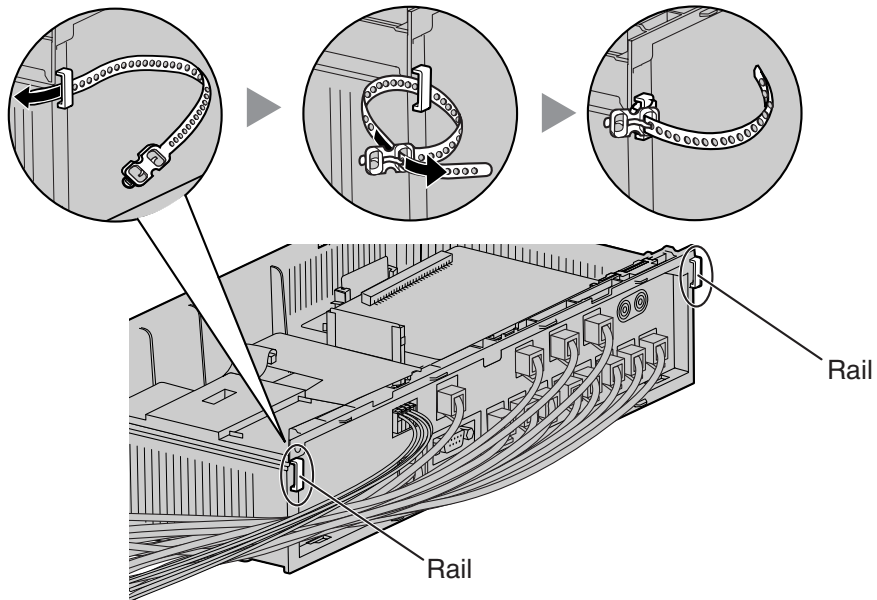

2. Bind the cables as shown.

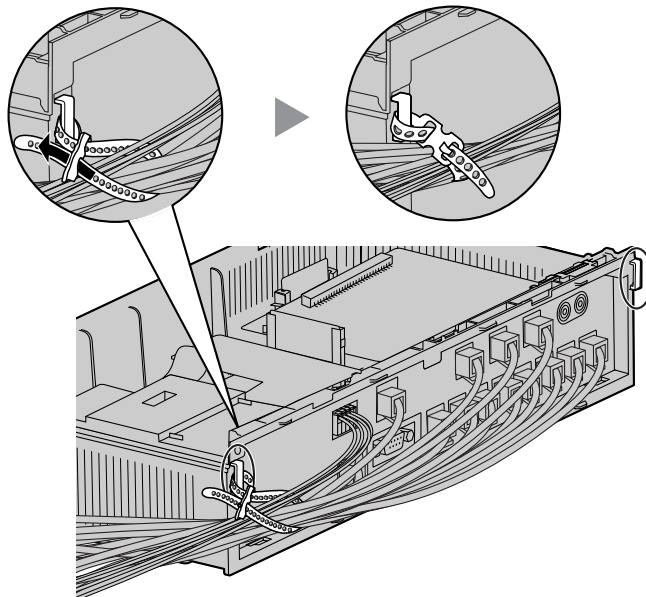

2.2 Installing the Advanced Hybrid System

3. Attach the cable cover. (→ 2.2.3 Opening/Closing Covers)

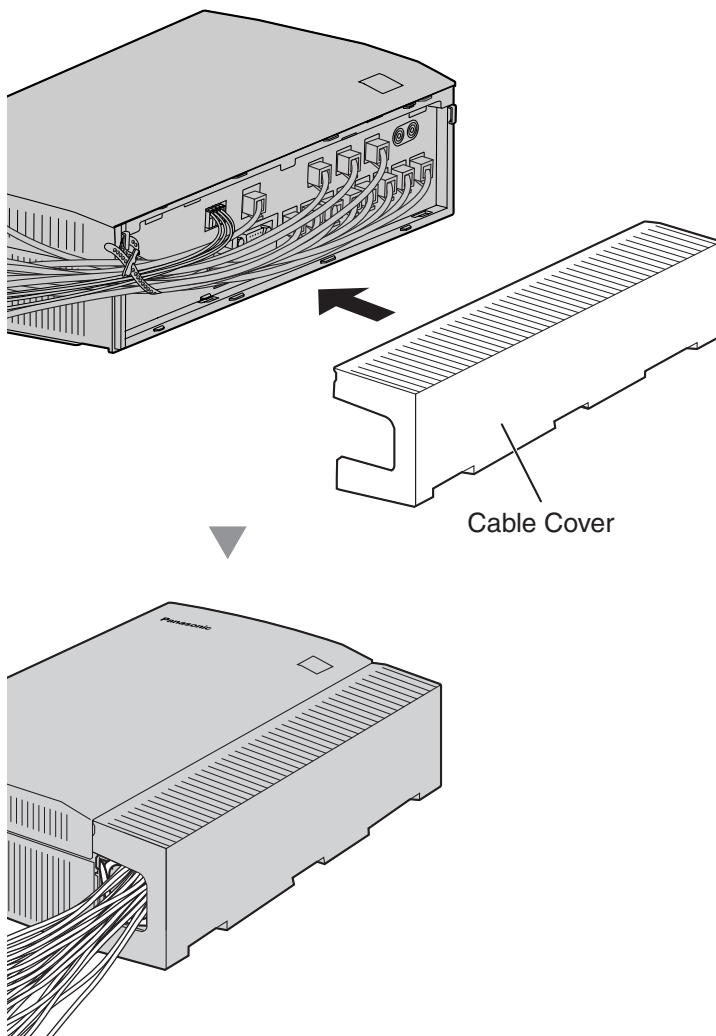

Notes

- For safety reasons, do not stretch, bend, or pinch the cables.
- If you prefer, you can cut the other side of the cable cover and run the cables through that opening. For safety reasons, smooth the cut edges.

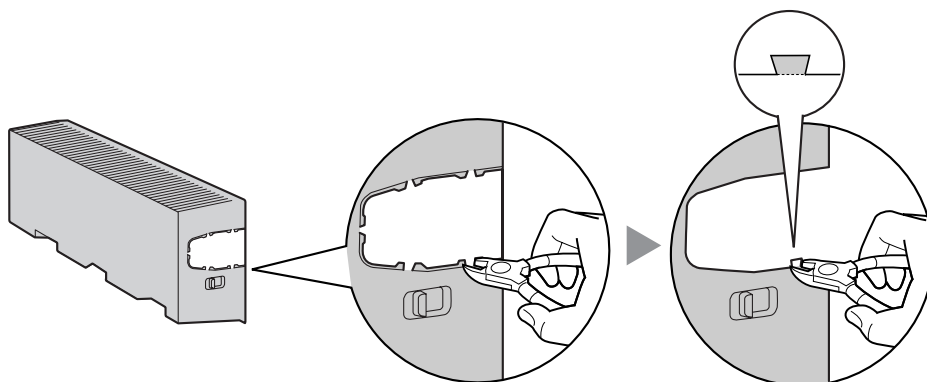

2.2.5 Connecting Frame Earth

IMPORTANT

Connect the frame of the PBX to earth.

1. Loosen the screw.
2. Insert an earthing wire (user-supplied)*.
3. Tighten the screw.
4. Connect the earthing wire to earth.

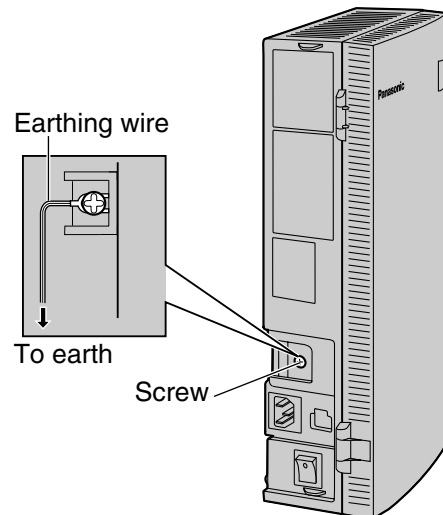

* Use an earthing wire that has a conductor with a cross-sectional area of at least 0.75 mm² or 18 AWG. Green-and-yellow insulation is required.

- Be sure to comply with all applicable laws, regulations, and guidelines.
- Proper earthing is very important to protect the PBX from external noise and to reduce the risk of electrocution in the event of a lightning strike.
- The AC cable's earthing pin may not be enough to protect the PBX from external noise and lightning strikes. A permanent connection must be made between earth and the earth terminal of the main unit.

2.2.6 Connecting Backup Batteries

Backup batteries and a backup battery cable provide a backup power supply to allow full use of the PBX in the event of a power failure. In case of power failure, the backup batteries automatically maintain the power for the PBX without interruption.

1. Set the Power Switch of the PBX to the "OFF" position and disconnect the AC cord from the AC outlet.
2. Connect the backup battery cable with 2 identical backup batteries.

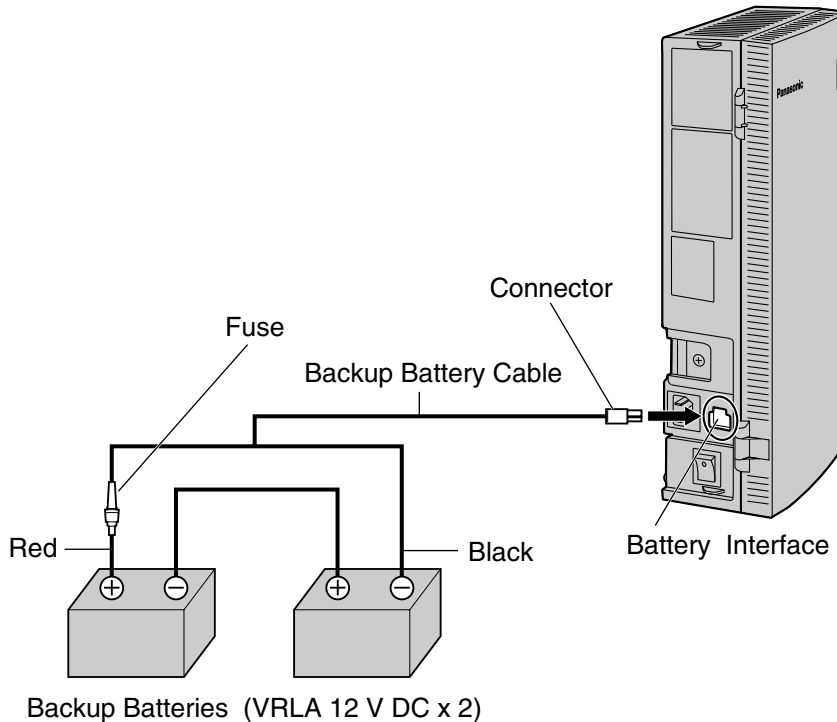

User-supplied Items

- Backup Batteries: VRLA (Valve Regulated Lead Acid) 12 V DC x 2
- Backup Battery Cable: KX-A227

CAUTION

- Be sure to comply with all applicable laws, regulations, and guidelines.
- Make sure that the polarities of the backup batteries and wiring are correct.
- Make sure that you do not short the backup batteries or cables.
- When replacing one of the batteries, use only the same or equivalent battery type recommended by the battery manufacturer. There is a danger of explosion if the backup batteries are incorrectly replaced.
Dispose of used batteries according to the manufacturer's instructions.
- The charging time of your battery varies depending on the charge remaining, the characteristics of the battery charger, and the ambient temperature.
Refer to the instructions provided by the battery manufacturer for details.
The following is an example calculation of the time needed to charge a drained battery (Battery rating: 7.2 Ah) connected to the PBX:

$$\begin{aligned} \text{Charging Time (h)} &= \frac{\text{Battery Rating 7.2 (Ah)}}{\text{Initial Charging Current typ. 0.3 (A)}} \times 1-3 \\ \text{(h: hours)} &= 24-72 \text{ (h)} \end{aligned}$$

Notes

- Turn on the power switch of the PBX only after the installation of the PBX is finished and AC cord is plugged into the AC outlet.
- For each backup battery, battery capacity of 14 Ah or below is recommended.
- Make sure that the type and capacity of the 2 backup batteries are identical.
- The backup battery cable should not be exposed to direct sunlight. Keep the backup battery cable and the backup batteries away from heating appliances and fire. Place the backup batteries in ventilated place.
- For details about the backup batteries, refer to the manual intended for the batteries.

2.2.7 Wall Mounting

The PBX is designed for wall mounting only. The wall where the PBX is to be mounted must be able to support the weight of the PBX. When wall mounting the main unit, use either the included screws, or screws of the same size.

Mounting on a Wooden Wall

The included screws may be used when mounting the main unit on a wooden wall.

1. Place the template (found on the last page of this manual) on the wall to mark the 3 screw positions.

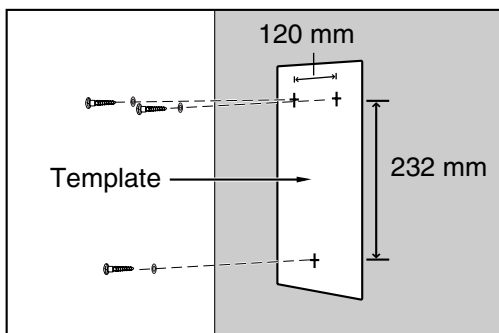

Note

When you print out the template, the distance on the paper output may deviate slightly from the indicated measurement. In this case, use the indicated measurement.

2. Fit the washers on the screws, and drive the screws into the wall.

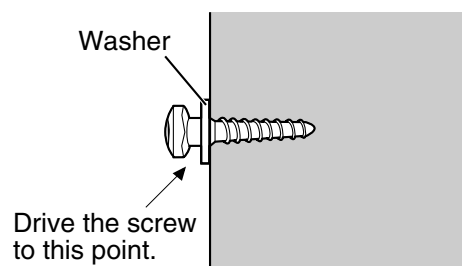

3. Affix the PBX to the screw heads.

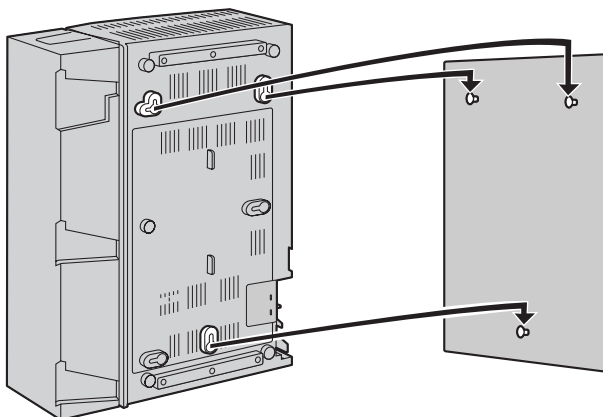

Notes

- Do not block the openings of the cabinet. Leave at least 20 cm of space above and 10 cm to the sides of the PBX for ventilation.
- Make sure that the wall behind the cabinet is flat and free of obstacles, so that the openings on the back of the cabinet will not be blocked.
- Be careful not to drop the cabinet.

Mounting on a Concrete or Mortar Wall

The included screws may be used when mounting the main unit on a concrete or mortar wall. User-supplied anchor plugs are also necessary.

1. Place the template (found on the last page of this manual) on the wall to mark the 3 screw positions.

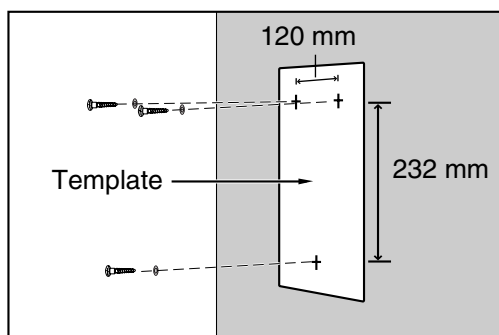
**Note**

When you print out the template, the distance on the paper output may deviate slightly from the indicated measurement. In this case, use the indicated measurement.

2. Drill holes in the wall as marked and fit the anchor plugs (not included) into the holes.

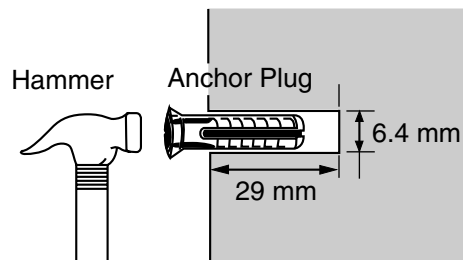

3. Fit the washers on the screws, and drive the screws into the anchor plugs.

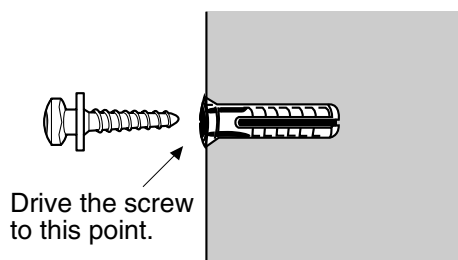

2.2 Installing the Advanced Hybrid System

4. Affix the PBX to the screw heads.

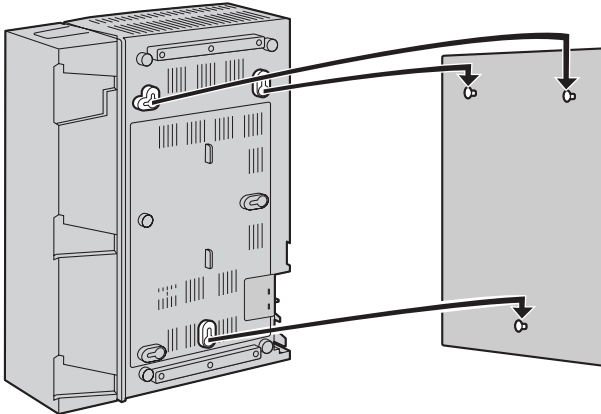

Notes

- Do not block the openings of the cabinet. Leave at least 20 cm of space above and 10 cm to the sides of the PBX for ventilation.
- Make sure that the wall behind the cabinet is flat and free of obstacles, so that the openings on the back of the cabinet will not be blocked.
- Be careful not to drop the cabinet.

2.2.8 Installing Surge Protector

Overview

A massive electrical surge can be caused if lightning strikes a telephone cable 10 m above ground, or if a telephone line comes into contact with a power line. A surge protector is a device that is connected to an outside (CO) line to prevent potentially dangerous electrical surges from entering the building via the outside (CO) lines and damaging the PBX and connected equipment.

To protect the PBX from electrical surges, we strongly recommend connecting the PBX to a surge protector that meets the following specifications:

- Surge arrestor type: 3-electrode arrestor
- DC spark-over voltage: 230 V
- Maximum peak current: at least 10 kA

Additionally, proper earthing is very important for the protection of the PBX. (→ 2.2.5 Connecting Frame Earth)

Many countries/areas have regulations requiring surge protection. Be sure to comply with all applicable laws, regulations, and guidelines.

Installation

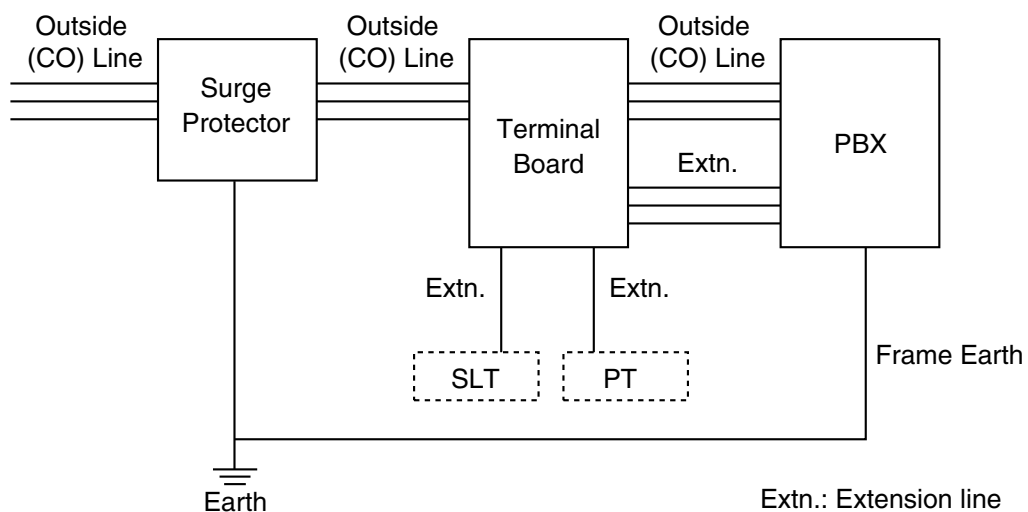

Outside Installation

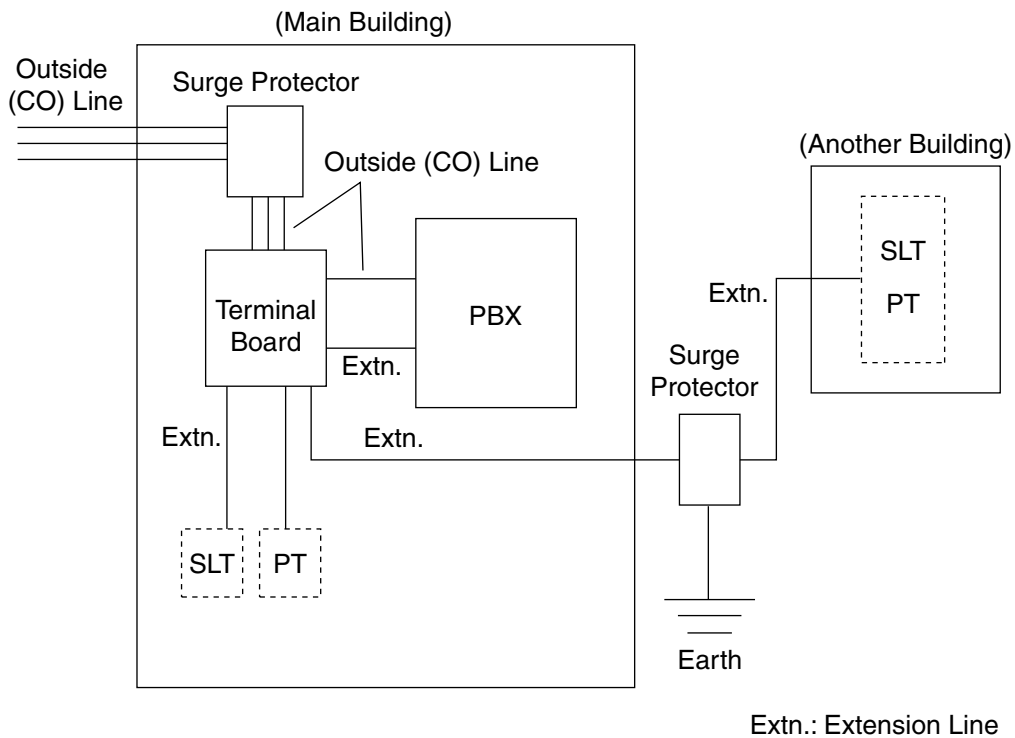

If you install an extension outside of the building, the following precautions are recommended:

- a. Install the extension wire underground.
- b. Use a conduit to protect the wire.

Note

The surge protector for an extension is different from that for an outside (CO) line.

Installation of an Earth Rod

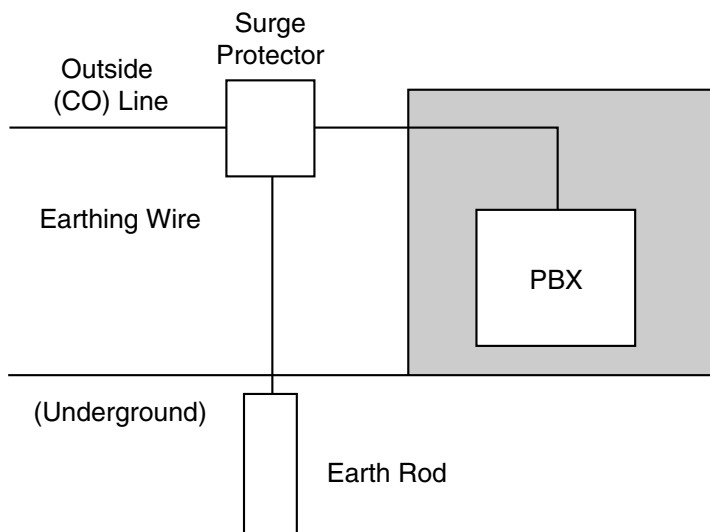

1. Connect the earth rod to the surge protector using an earthing wire with a cross-sectional area of at least 1.3 mm².

2. Bury the earth rod near the protector. The earthing wire should be as short as possible.
3. The earthing wire should run straight to the earth rod. Do not run the wire around other objects.
4. Bury the earth rod at least 50 cm underground.

Notes

- The above figures are recommendations only.
- The length of the earth rod and the required depth depend on the composition of the soil.

2.3 Installing Optional Service Cards

2.3.1 Location of Optional Service Cards

Optional service cards are installed by opening the cable and front covers of the main unit and affixing the cards to the appropriate connectors. Each card should be installed in the appropriate location as shown below.

See "System Components Table" for the description of each optional service card.

CAUTION

To protect the printed circuit boards (P-boards) from static electricity, do not touch parts on the P-boards in the main unit and on the optional service cards. If you must touch the P-boards, wear an earthing strap.

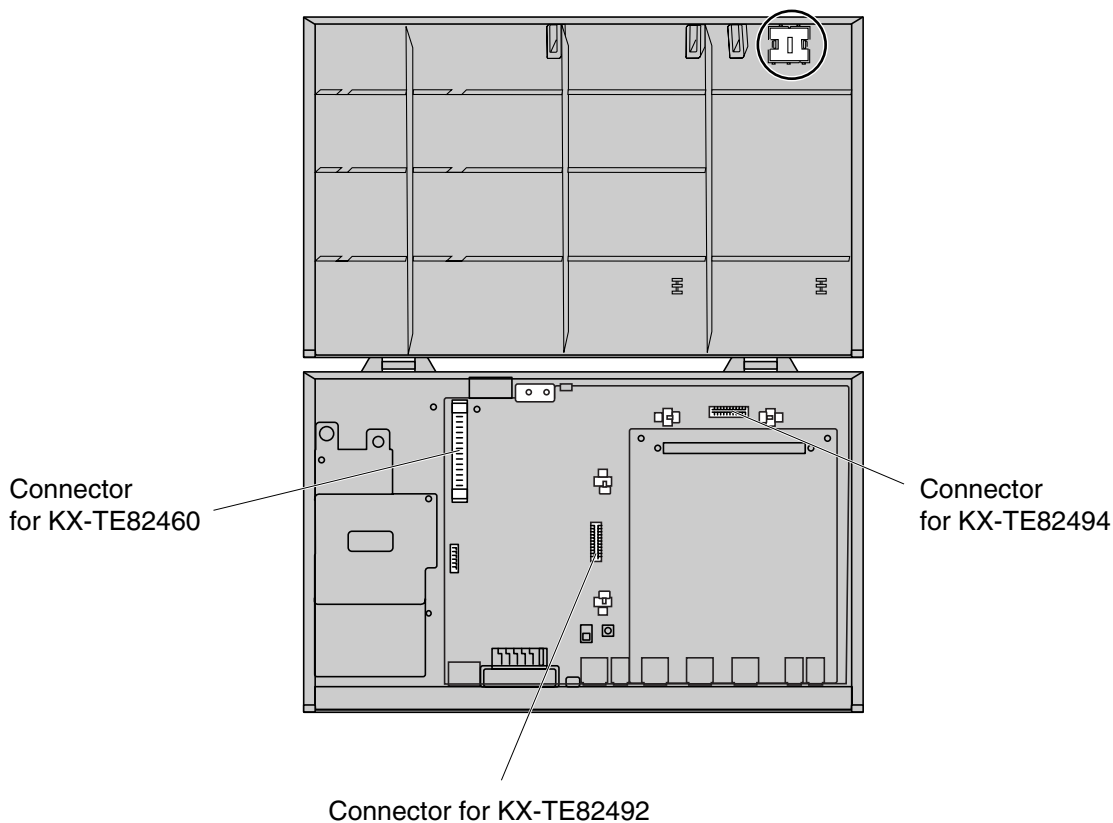

Notes

- Before installing optional service cards, turn off the PBX and unplug the AC cord.
- Use extra care to make sure you do not damage the part of the case marked with a circle.

2.3.2 3-Port Caller ID Card (KX-TE82494)

Function

Adds Caller ID support for 3 outside (CO) lines.

FSK (Frequency Shift Keying) and DTMF (Dual Tone Multi-Frequency) Caller ID types are supported. For information on the type of Caller ID used in your area, contact your telephone company.

1. Loosen the screws and open the cable and front covers. (→ 2.2.3 Opening/Closing Covers)
2. Slide the card between the guiderails until it clicks, and attach the connector to it.

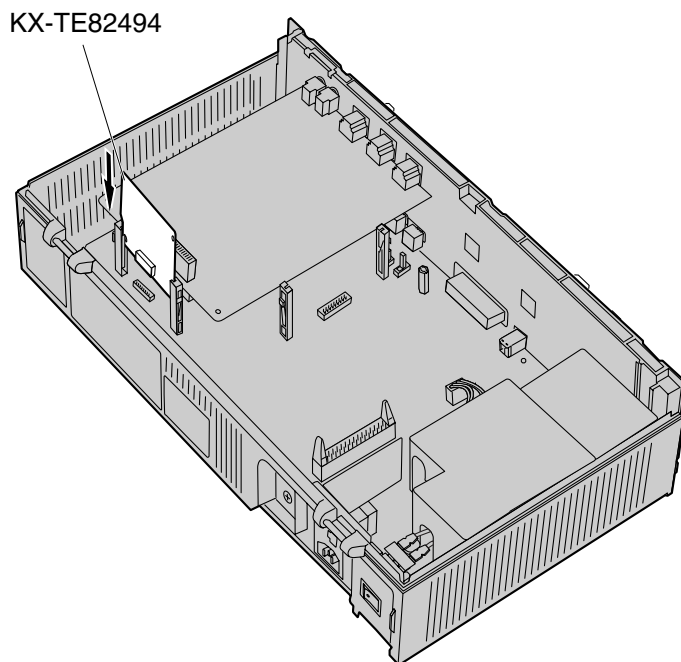

3. Close the covers and secure the screws. (→ 2.2.3 Opening/Closing Covers)

Note

To uninstall the card, follow the instructions illustrated below.

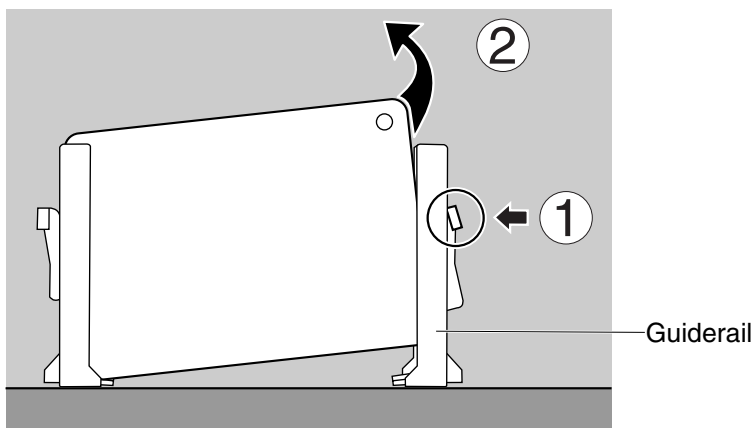

1. Push the catch on the side of one guiderail in the direction of the arrow to release it.

2.3 Installing Optional Service Cards

2. Lift the edge of the card while holding the catch open. (Do not touch the circuit board of the card during the operation.)

2.3.3 2-Port Doorphone Card (KX-TE82460)

Function

Supports the connection of 2 doorphones and 2 door openers.

- 1. Loosen the screws and open the cable and front covers. (→ 2.2.3 Opening/Closing Covers)
- 2. Before installing the optional service card, cut and remove the dummy cover from the main unit.

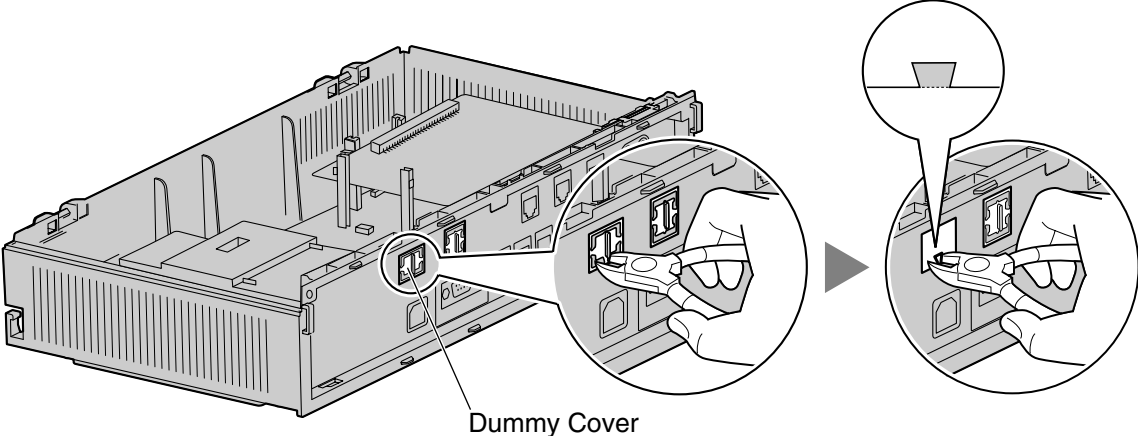

- 3. Attach the 2-Port Doorphone Card to the main unit, connect the cord to the Doorphone Card Connector and secure the screws.

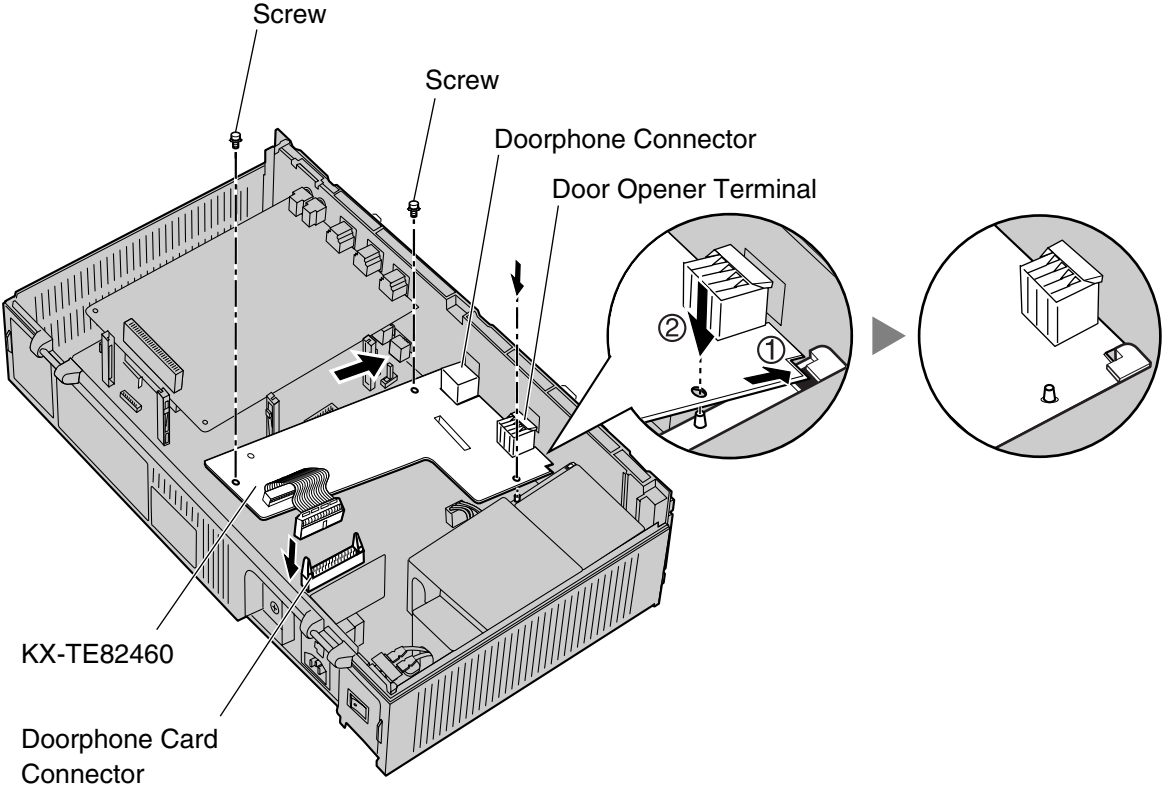

- 4. Close the covers and secure the screws. (→ 2.2.3 Opening/Closing Covers)

2.3.4 2-Channel Voice Message Card (KX-TE82492)

Function

Provides 60 minutes of recording time (2 channels) for messages using the Built-in Voice Message Feature.

1. Loosen the screws and open the cable and front covers. (→ 2.2.3 Opening/Closing Covers)
2. Slide the card between the guiderails until it clicks, and attach the connector to it.

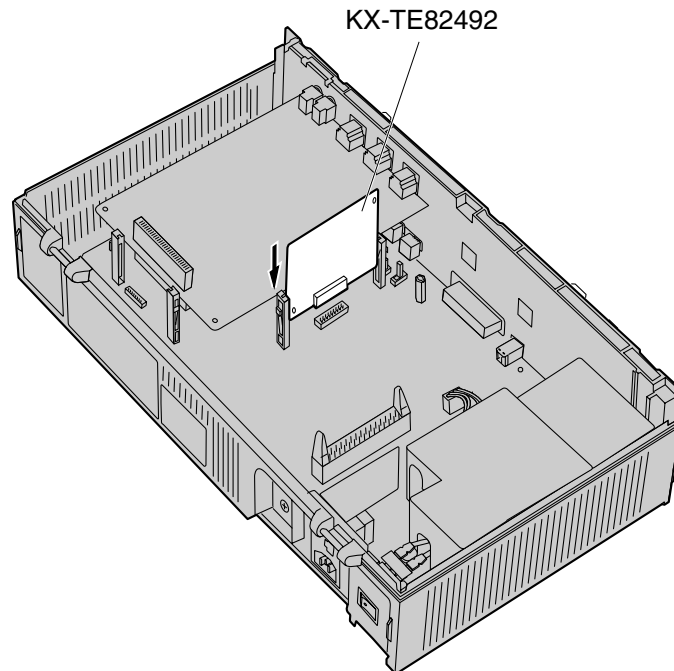

3. Close the covers and secure the screws. (→ 2.2.3 Opening/Closing Covers)
4. Initialise the 2-Channel Voice Message Card through system programming. (→ 2.10.1 Starting the Advanced Hybrid System)

Note

To uninstall the card, follow the instructions illustrated below.

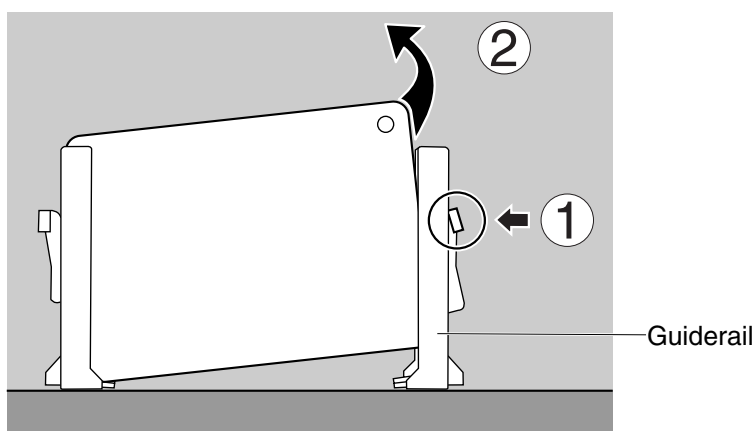

1. Push the catch on the side of one guiderail in the direction of the arrow to release it.

2. Lift the edge of the card while holding the catch open. (Do not touch the circuit board of the card during the operation.)

2.4 Connecting Outside (CO) Lines

2.4.1 Connecting Outside (CO) Lines

Connection

1. Insert the modular plugs of the telephone line cords (2-conductor wiring) into the outside (CO) line jacks.
2. Connect the line cords to the terminal board or the modular jacks from the telephone company.

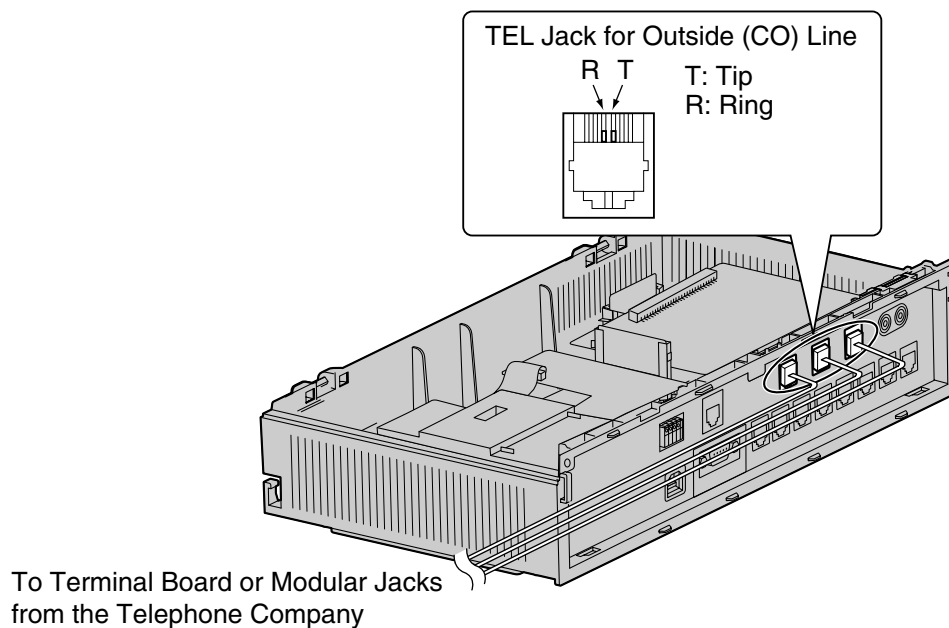

2.5 Connecting Extensions

2.5.1 Connecting Extensions

Extension jacks can be used for proprietary telephones (PTs), Direct Station Selection (DSS) Consoles, single line telephones (SLTs), and Voice Processing Systems.

Note

Connect a display-equipped PT to extension jack 01, as this extension is automatically designated as the manager extension.

Connection

Insert the modular plugs of the telephone line cords (2- or 4-conductor wiring) into the modular jacks on the PBX.

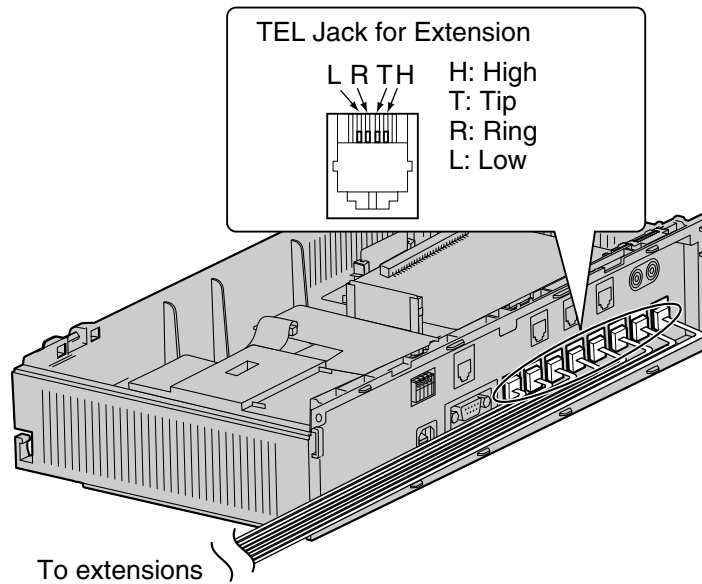

Maximum Cabling Distance of Extension Wiring (Twisted Cable)

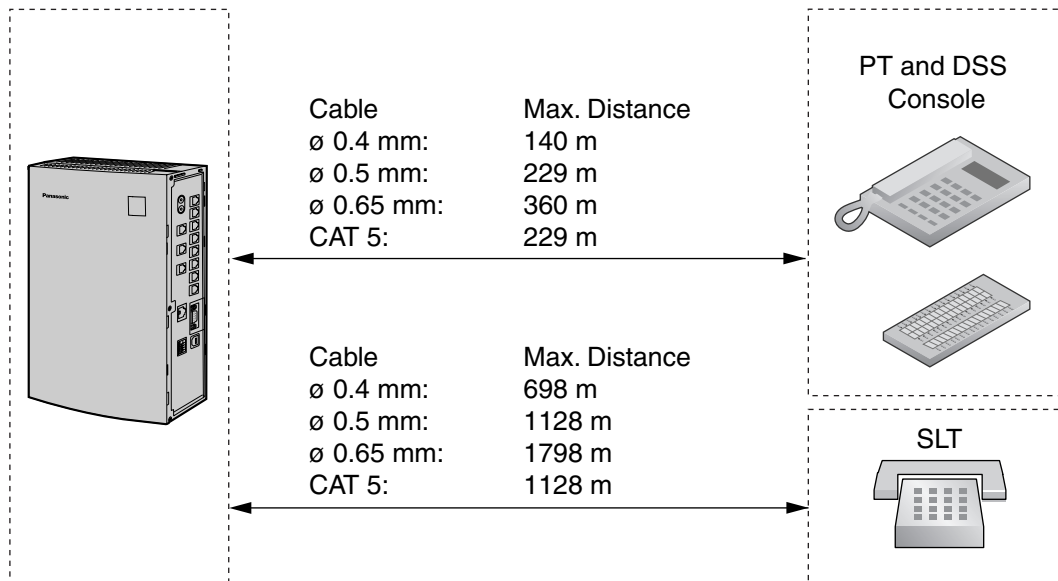

2- or 4-conductor wiring is required for each extension as listed below. There are 4 pins that can be used for connection: "T" (Tip), "R" (Ring), "H" (High) and "L" (Low).

Telephone	Wiring
SLT	1-pair wire (T, R)
PT (such as KX-T7735)	2-pair wire (T, R, H, L)
DSS Console	1-pair wire (H, L)

Note

If a telephone or answering machine with an A-A1 relay is connected to the PBX, set the A-A1 relay switch on the telephone or answering machine to the "OFF" position.

2.5.2 Connecting Extensions in Parallel

Any single line telephone (SLT) can be connected in parallel with a proprietary telephone (PT) to a Hybrid Port as follows:

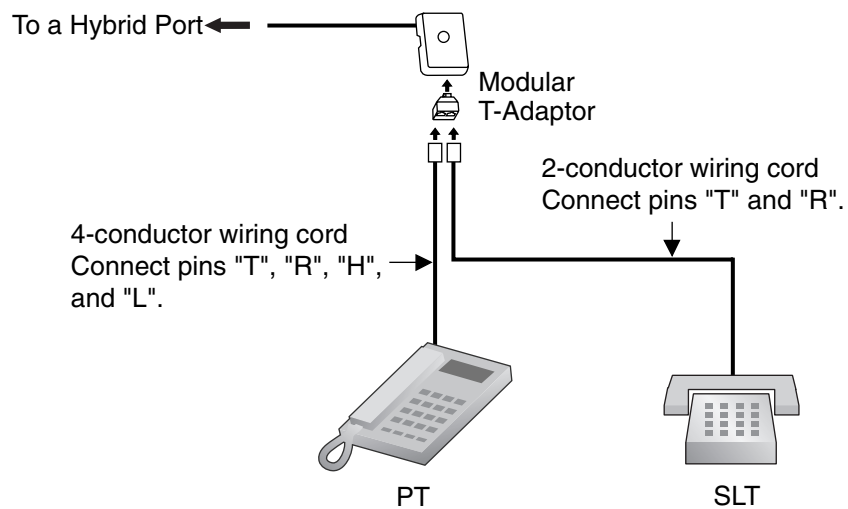

Note

An answering machine, fax machine or modem can be connected in parallel with a PT in the same way as an SLT can.

2.6 Connecting Doorphones and Door Openers

2.6.1 Connecting Doorphones and Door Openers

Up to 2 doorphones (KX-T30865) and 2 door openers (user-supplied) can be installed.

Maximum Cabling Distance

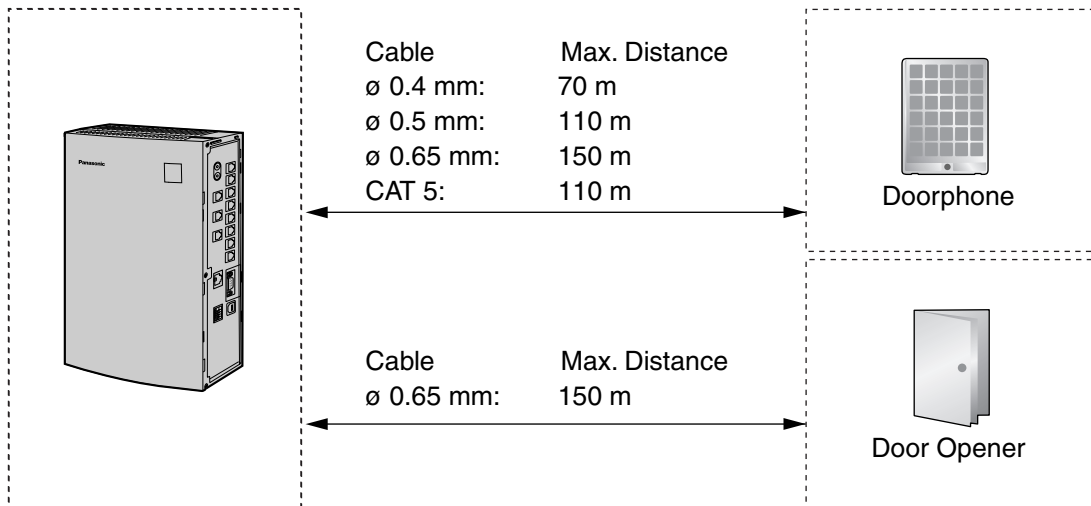

Door opener current limit: 30 V DC/30 V AC, 3 A maximum

Installing the Doorphone (KX-T30865)

1. Loosen and remove the screw at the bottom of the case to separate the doorphone into 2 halves.

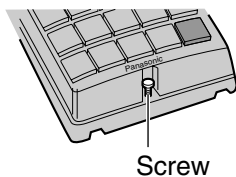

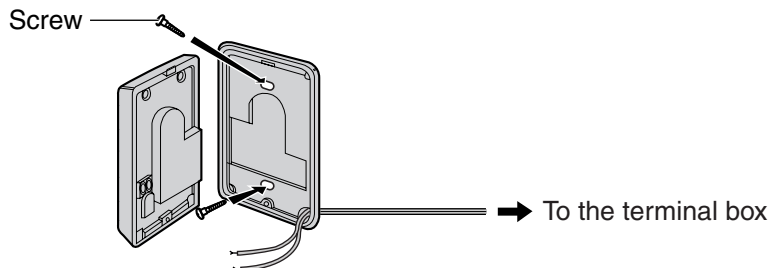

2. Pass the wires through the hole in the base cover, and attach the base cover to a wall using 2 screws.



Note

2 kinds of screws are included with the KX-T30865. Please choose the appropriate screws for your wall type.

 : when a doorphone plate has been fixed to the wall

 : when you wish to install the doorphone directly to the wall

3. Connect the wires to the screws located in the front cover.

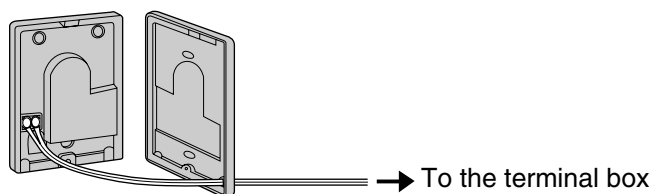

4. Re-attach the 2 halves and re-insert and tighten the screw.

Connecting Doorphones (KX-T30865)

1. Connect the Doorphone Card to the terminal box using 4-conductor wiring and modular connectors.
2. Connect the wires of doorphone 1 to the red and green screws on the appropriate terminal box.
3. Connect the wires of doorphone 2 to the yellow and black screws on the appropriate terminal box.

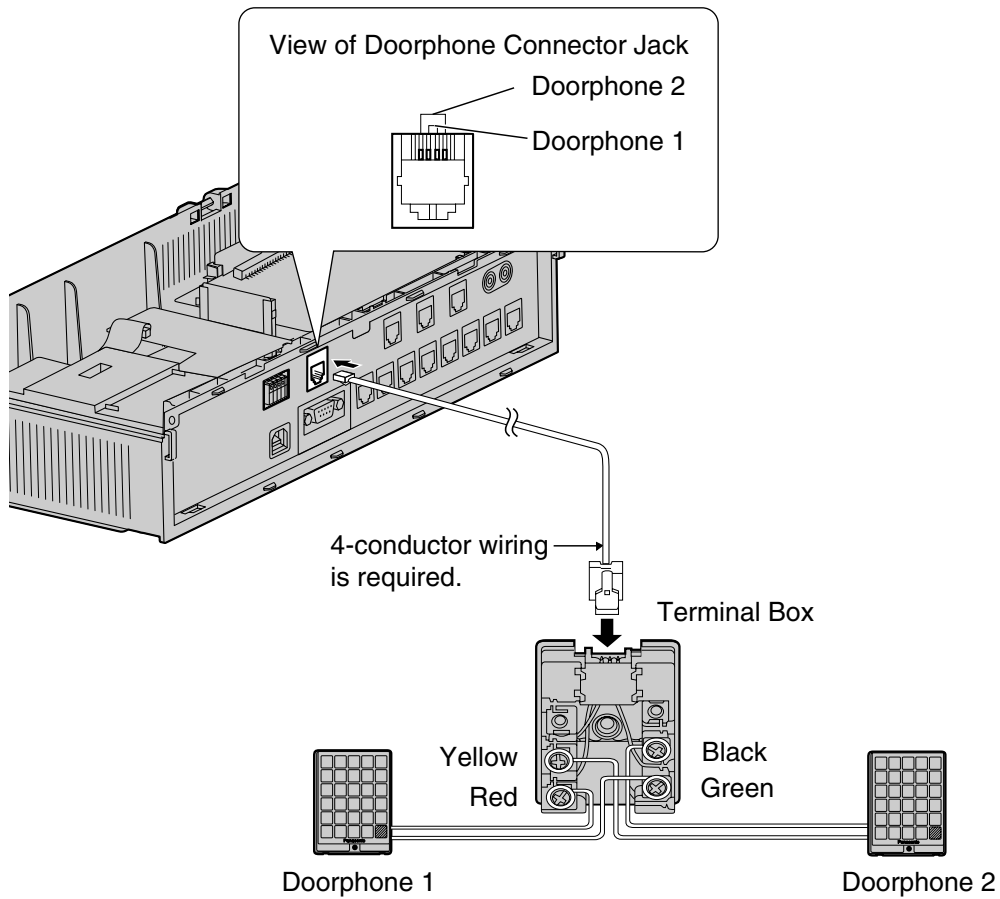

Connecting Door Openers

1. Use a flathead screwdriver to press and hold open the button below the terminal, and insert the wire coming from the door opener into the terminal.

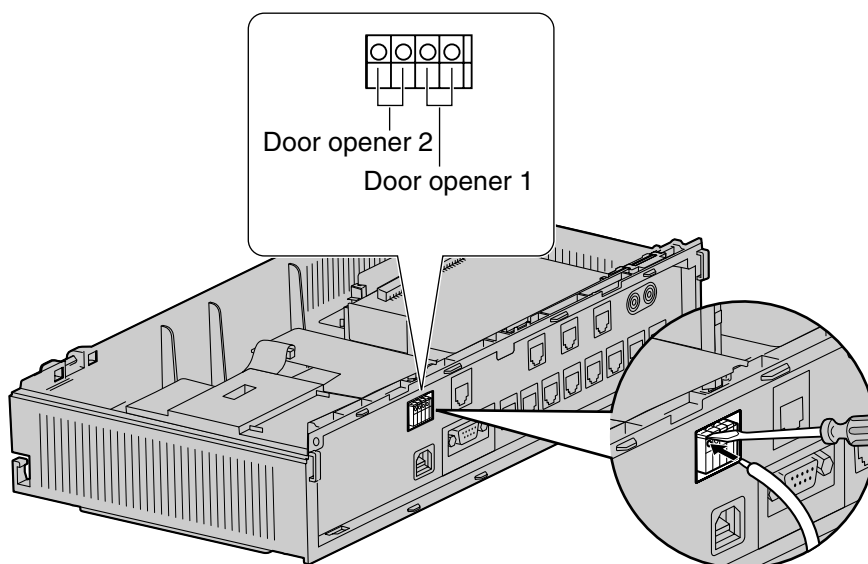

To the door openers

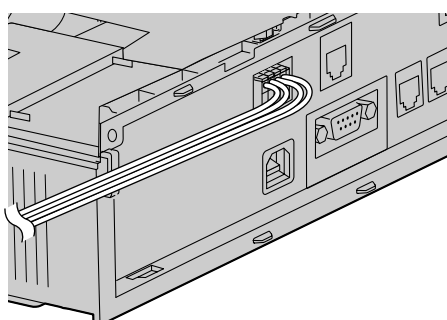

2. Wrap the strap around all of the cords. (→ 2.2.4 Securing the Cables)

Notes

- We recommend using UL1015 wire or an equivalent for wiring.
- The wire should be between 0.45 mm and 1.1 mm in diameter excluding the coating.

2.7 Connecting Doorbell or Door Chime

2.7.1 Connecting Doorbell or Door Chime

Use a flathead screwdriver to press and hold open the button below the terminal, and insert the wire coming from the doorbell or door chime into the terminal. You can use a standard doorbell/door chime.

Refer to "2.6 Connecting Doorphones and Door Openers" for connecting doorphones (KX-T30865) and door openers.

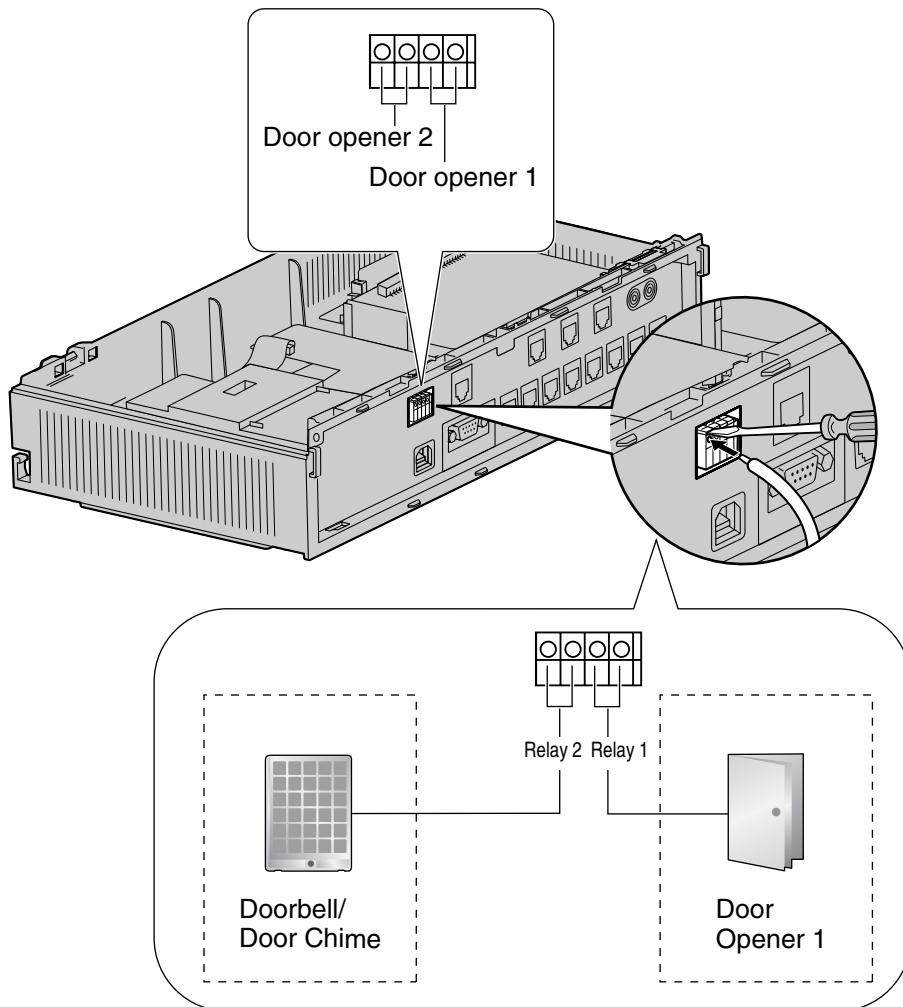

2.8 Connecting Peripherals

2.8.1 Connecting Peripherals

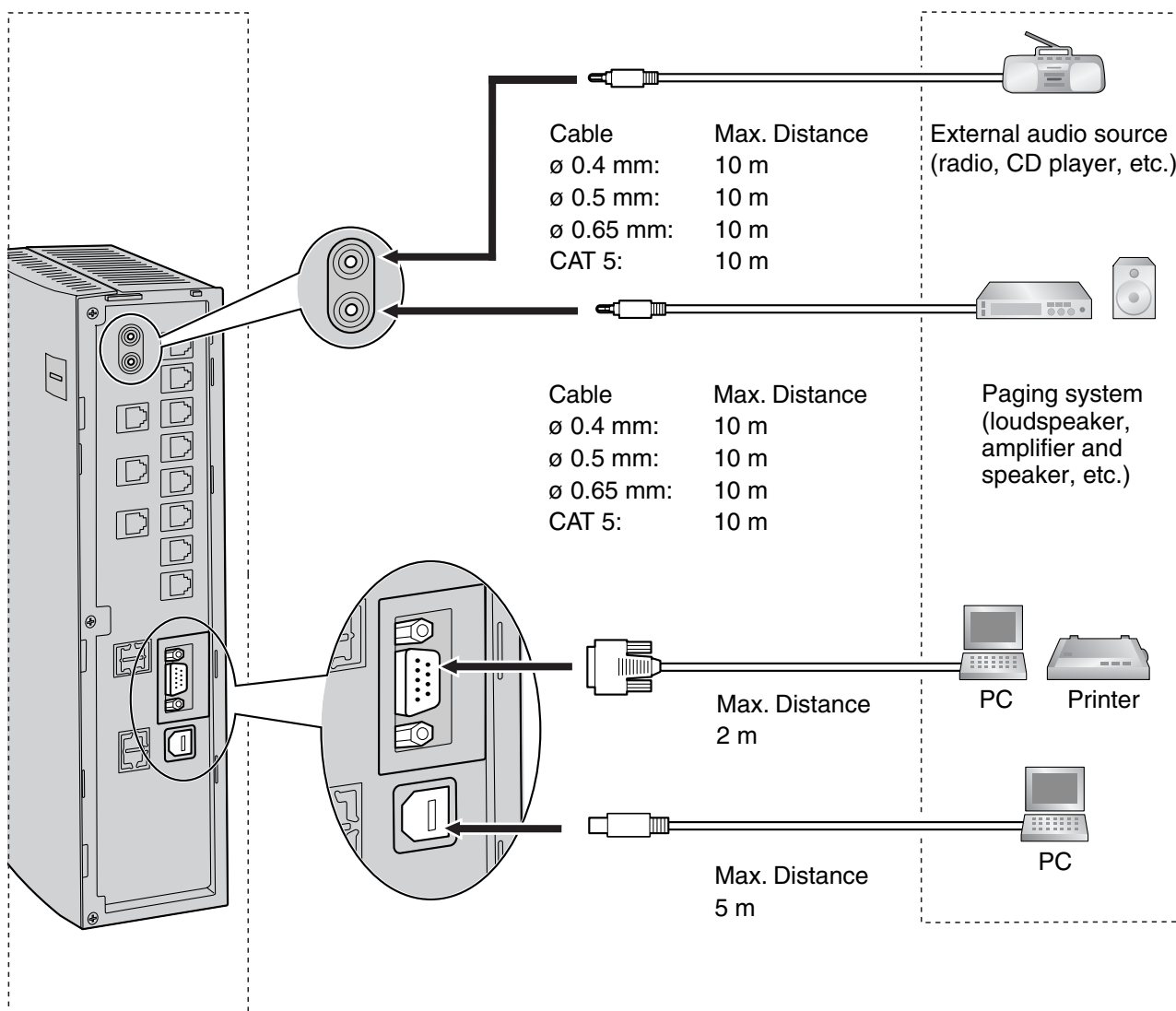

Note

Be sure to comply with the above maximum distance between the PBX and each peripheral.

BGM/MOH

1 audio source (user-supplied), such as a radio or CD player, can be connected to the PBX and used as the source of Background Music (BGM) and Music on Hold (MOH).

Connect a cable from the audio output (earphone jack, headphone jack, etc.) of the audio source to

2.8 Connecting Peripherals

the MOH Jack of the PBX.

Use an EIAJ RC-6701 A plug (2-conductor, 3.5 mm in diameter).

- Input impedance: 8 Ω

CAUTION

- Do not force audio cables into the jacks. Doing so may damage the connections and cause the audio to cut in and out.
- The MOH port is an SELV port and should only be connected to an approved SELV device.

Notes

- Use an audio cable connector of the appropriate size. Some long audio cable connectors may not fit when the cable cover of the PBX is closed.
- When the PBX and external audio source are not connected to the same earth, a humming noise may be heard in the BGM and MOH.
- The audio source used for BGM and MOH is determined by system programming.
- To adjust the sound level of the MOH, use the volume control on the external audio source.

Pager

Only 1 paging device (user-supplied) can be connected to the PBX.

Use an EIAJ RC-6701 A plug (2-conductor, 3.5 mm in diameter).

- Output impedance: 600 Ω

CAUTION

The External Paging Jack is an SELV port and should only be connected to an approved SELV device.

Notes

- Use a pager cable connector of the appropriate size. Some long pager cable connectors may not fit when the cable cover of the PBX is closed.
- To adjust the sound level of the pager, use the volume control on the loudspeaker or amplifier.

PC/Printer (via RS-232C)

A PC can be connected via the RS-232C interface and used to log and display call records, and programme the PBX. A printer can also be connected, to print call records.

Connect the PC or printer via an RS-232C cable (user-supplied).

Note

Use an RS-232C cross cable when connecting the PBX with a PC.

Pin Assignments

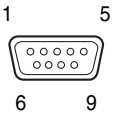
	No.	Signal Name	Function	Circuit Type	
				EIA	CCITT
	2	RD (RXD)	Receive Data	BB	104
	3	SD (TXD)	Transmit Data	BA	103
	4	ER (DTR)	Data Terminal Ready	CD	108.2
	5	SG	Signal Ground	AB	102
	6	DR (DSR)	Data Set Ready	CC	107
	7	RS (RTS)	Request To Send	CA	105
	8	CS (CTS)	Clear To Send	CB	106

Connection Charts

For connecting a PC/printer with a 9-pin RS-232C connector

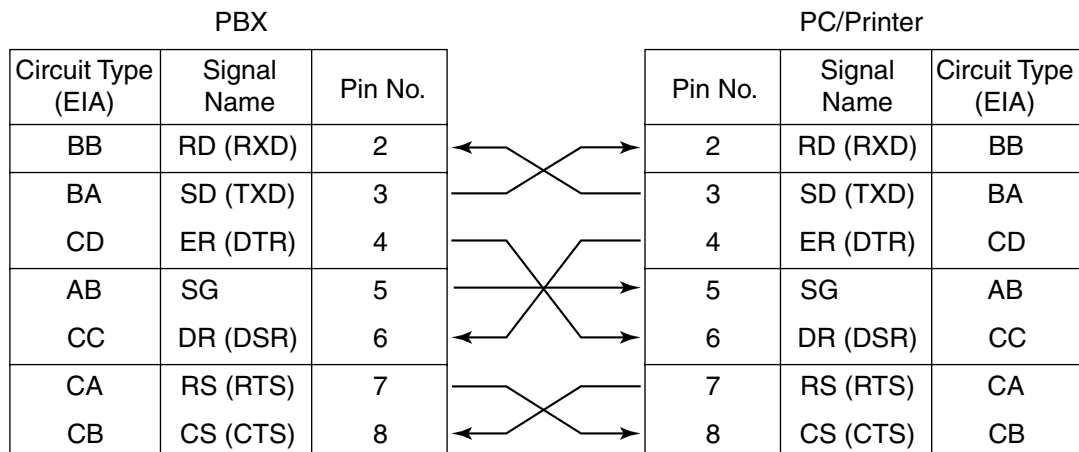

For connecting a PC/printer with a 25-pin RS-232C connector

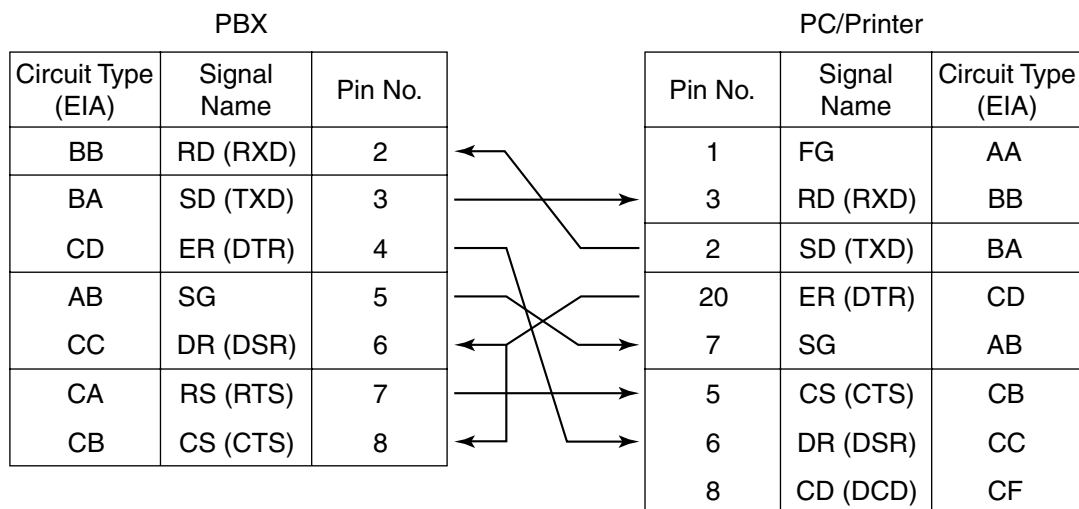

RS-232C Signals

- **Receive Data (RXD):...**(input)
Carries signals from the printer or the PC to the PBX.
- **Transmit Data (TXD):...**(output)
Carries signals from the PBX to the printer or the PC. Stays in "Mark" status unless data or BREAK signals are being transmitted.
- **Data Terminal Ready (DTR):...**(output)
This signal line is turned ON by the PBX to indicate that it is ON LINE. Circuit ER (DTR) ON does not indicate that communication has been established with the printer or the PC. It is switched OFF when the PBX is OFF LINE.
- **Signal Ground (SG)**
Connects to the DC ground of the PBX for all interface signals.
- **Data Set Ready (DSR):...**(input)
An ON condition of circuit DR (DSR) indicates that the printer or the PC is ready. Circuit DR (DSR) ON does not indicate that communication has been established with the printer or the PC.
- **Request To Send (RTS):...**(output)
This is held ON whenever DR (DSR) is ON.
- **Clear To Send (CTS):...**(input)
An ON condition of circuit CS (CTS) indicates that the printer or the PC is ready to receive data from the PBX. The PBX does not attempt to transfer data or receive data when circuit CS (CTS) is OFF.
- **Frame Ground (FG)**
Connects to the unit frame and the earth ground conductor of the AC cord.
- **Data Carrier Detect (DCD):...**(input)
An ON condition of circuit CD (DCD) indicates the data terminal (DTE) that the carrier signal is being received by.

PC (via USB 1.1 interface)

A PC running the KX-TEA308 Maintenance Console software can be connected via the USB interface and used to programme the system and upload/download data to the PBX.

Pin Assignments

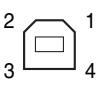
	No.	Signal Name
	1	VBUS
	2	USB D-
	3	USB D+
	4	GND

2.9 Power Failure Connections

2.9.1 Power Failure Connections

When the power supply to the PBX fails, power failure transfer will switch from the current connection to the Power Failure Connections.

Power Failure Connections connect a specific extension and an outside (CO) line in the event of power failure as follows:

Outside (CO) line 1—extension (T, R) jack 01

Notes

- In the event of a power failure, system memory is protected by a factory-provided lithium battery. No system data will be lost, except for the Camp-on, Saved Number Redial, Last Number Redial, and Call Park data.
- The current connection automatically switches to the Power Failure Connection when the power supply stops.
- Proprietary telephones (PTs) cannot be used during a power failure. Therefore, we recommend connecting a single line telephone (SLT) in parallel with a PT to extension jack 01.
Note that if the paralleled SLT is on an outside (CO) line call when the power is restored, that call will be disconnected.
- As long as DC power is provided by the backup batteries, the PBX will remain fully operational and the connection will not switch to the Power Failure Connections.

2.10 Starting the Advanced Hybrid System

2.10.1 Starting the Advanced Hybrid System

This section explains the required procedure for starting the PBX for the first time, or when using the optional 2-Channel Voice Message Card (KX-TE82492) for the first time.

1. Make sure that all outside (CO) lines you use are connected to the PBX.
2. Set the Power Switch to the "OFF" position.
3. If installing the 2-Channel Voice Message Card, insert it into the PBX. (→ 2.3.4 2-Channel Voice Message Card (KX-TE82492))
4. Connect the AC cord to the PBX, then plug the AC cord into an AC outlet.
5. Set the Power Switch to the "ON" position.

Note

For safety reasons, do not stretch, bend, or pinch the AC cord.

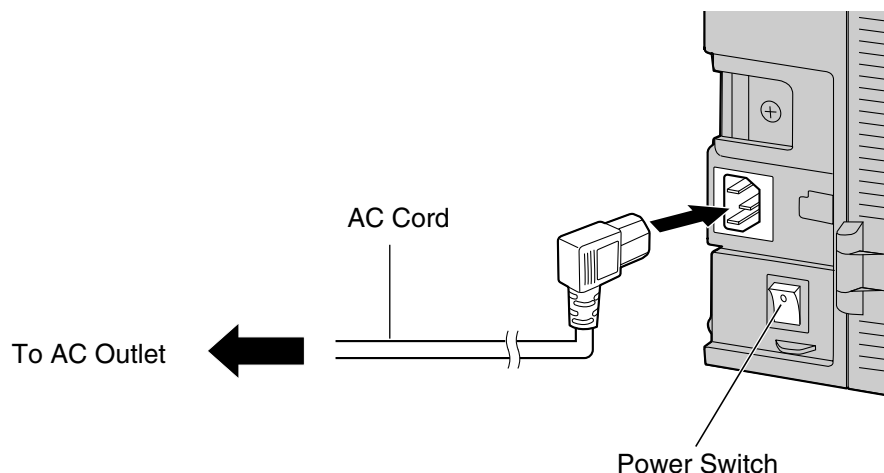

6. Enter system programming mode.
 - a. Connect a proprietary telephone (PT) to extension jack 01 of the PBX.
 - b. Press the PROGRAM button.
 - c. Press * #.
 - d. Enter your System Password (Default: 1234).
7. Perform the following procedure,
[when starting the PBX for the first time]
To initialise the PBX with the default values:
 - a. Enter 999.
 - b. Press the NEXT (SP-PHONE) button and "All Para" is displayed.
 - c. Press the STORE (AUTO DIAL/STORE) button.
 - d. Press the END (HOLD) button.

Notes

- The type of outside (CO) line is automatically detected.
- If the PBX does not function properly, refer to "4.1.5 System Reset with System Data Clear".

To clear outgoing messages (OGMs) for DISA/UCD:

- e. Enter 599.
- f. Press the NEXT (SP-PHONE) button.
- g. Press the STORE (AUTO DIAL/STORE) button.
- h. Press the END (HOLD) button.

[when using the 2-Channel Voice Message Card for the first time]

To initialise the 2-Channel Voice Message Card:

- a. Enter 808.
- b. Press the NEXT (SP-PHONE) button.
- c. Press the STORE (AUTO DIAL/STORE) button.
- d. Press the END (HOLD) button.

CAUTION

The 2-Channel Voice Message Card must be inserted before start up.

8. Press the PROGRAM button to exit system programming mode.
9. Programme the PBX using either one of the following methods:
 - a. PC programming. Refer to "Section 3, Guide for KX-TEA308 Maintenance Console".
 - b. PT programming. Refer to "3.3 PT Programming" of the Feature Guide. Users in countries such as Italy and the Czech Republic are required to set the country code prior to all other settings.

CAUTION

- The PBX is powered as long as the AC cord is plugged into an AC outlet, even if the Power Switch is set to the "OFF" position.
- The power supply cord is used as the main disconnect device. Ensure that the AC outlet is located/installed near the equipment and is easily accessible.

Notes

- If the outside (CO) lines you use are not connected to the PBX, outside (CO) line type cannot be automatically detected.
- Use only the AC cord included with the PBX.
- If the PBX will not be used for an extended period of time, set the Power Switch to the "OFF" position and disconnect the AC cord from the AC outlet to conserve power.

2.10 Starting the Advanced Hybrid System

Section 3

Guide for KX-TEA308 Maintenance Console

This section explains how to install and use KX-TEA308 Maintenance Console, a PC-based programming utility.

3.1 Installing KX-TEA308 Maintenance Console

3.1.1 Installing KX-TEA308 Maintenance Console on a PC

To programme and administer the PBX by PC (Personal Computer), you need to install KX-TEA308 Maintenance Console onto the PC.

System Requirements

Required Operating System

- Microsoft® Windows® 98 SE, Windows Me, Windows 2000, or Windows XP

Minimum Hardware Requirements

- CPU: 300 MHz Intel® Celeron® microprocessor
- HDD: 100 MB of available hard disk space
- RAM: 128 MB of available RAM

Setting the Password and Password Security

To maintain system security, a password is required to perform system programming. When KX-TEA308 Maintenance Console is started for the first time, the Quick Setup utility will ask you to set the system password. To avoid unauthorised access and possible fraudulent dialling, do not disclose the password.

Warning to the Installer regarding the system password

1. Please inform the customer of the importance of the password and the possible dangers if it becomes known to others.
2. To avoid unauthorised access and possible fraudulent dialling, maintain the secrecy of the password.
3. We strongly recommend that you change the default password value to something else for reasons of system security. It is best to use a password of 7 digits.
4. Please change the password periodically.
5. If a system password is forgotten, it can be found by loading a backup of the system data into a PC, and checking the password using the KX-TEA308 Maintenance Console software. If you do not have a backup of the system data, you must reset the PBX to its factory defaults and reprogramme it. Therefore, we strongly recommend maintaining a backup of the system data.

For more information on how to back up the system data, refer to the on-line help that appears by selecting the Help menu during PC programming. However, as system passwords can be extracted from backup copies of the system data file, do not allow unauthorised access to these files.

Note

This PBX has only one system password. It can be changed by either PT programming or PC programming. For this reason, the password can consist of numerals only.

Installing KX-TEA308 Maintenance Console

Notes

- Before installing or uninstalling the software, be sure to close any open applications.
- To install or uninstall the software on a PC running Windows 2000 Professional or Windows XP Professional, you must be logged in as a user in the "Administrators" group.

1. Insert the included CD-ROM into the CD-ROM drive of your PC.
The main screen will appear automatically.

2. Click **Maintenance Console**.



3. Double-click the setup file to run the installer. (Its icon is shown here, on the left.)

4. Follow the on-screen instructions provided by the installation wizard.

5. Select the appropriate model code. (The model code is the suffix attached to the model number.) The appropriate default data will be installed based on the model code selected here.

6. Click **Next**.

7. Follow the instructions of the wizard.

3.2 Connection

3.2.1 Connection

PBX features and settings can be customised using a PC and the KX-TEA308 Maintenance Console software.

Programming can be performed both on-site, using a PC connected directly to the PBX, and off-site, by accessing the PBX via modem.

Serial Interface Connection

A PC can be connected to the RS-232C port of the PBX, or to the USB port for faster access.

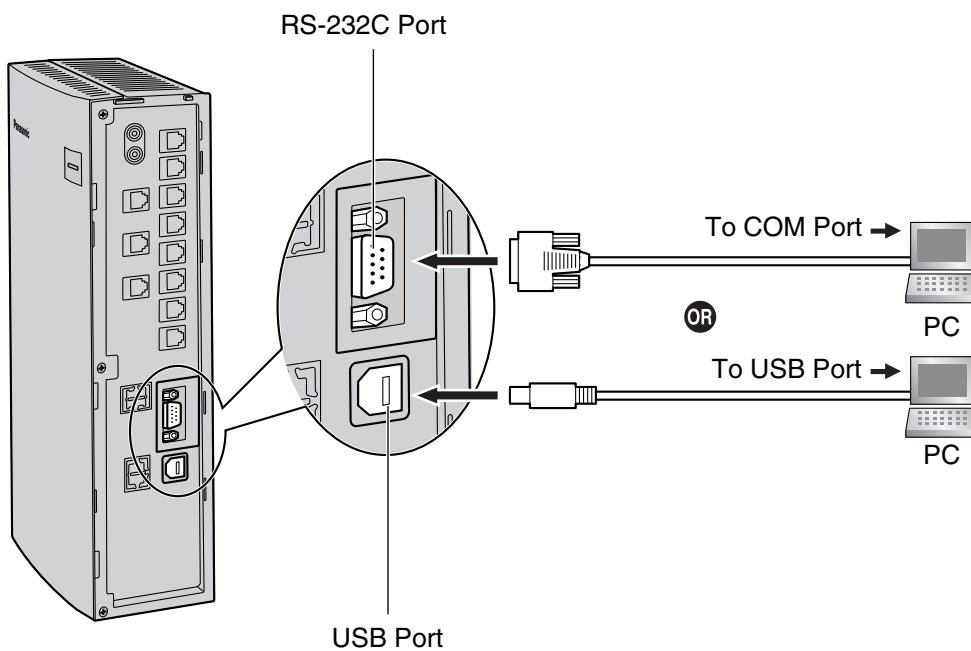

Notes

- For pin assignments and maximum cabling distance, refer to "2.8 Connecting Peripherals".
- When connecting the KX-TEA308 Maintenance Console to the PBX using an RS-232C cable, assign the following values to the Serial Interface (RS-232C) port of the PBX through system programming, "SMDR RS-232C Parameter [800]":
 - Baud Rate: 9600 bps
 - Word Length: 8 bits
 - Parity Bit: None
 - Stop Bit: 1 bit

Installing the USB Driver

CAUTION

Installing the USB driver may prevent the USB driver for KX-TDA series or PC Console/Phone Software from functioning correctly. In this case, update the USB drivers as necessary from the following folders on the included CD-ROM:

KX-TDA Series: CD-ROM Drive:\TDA_USB Driver\TDA_USB Driver
PC Console/Phone Software: CD-ROM Drive:\TDA_USB Driver\T7601_USB Driver

Note

Before installing or uninstalling the driver, be sure to close any open applications.

Windows 98SE

1. Connect the PC to the PBX with a USB cable.
The **Add New Hardware Wizard** will appear.
2. Click **Next**.
3. Select **Search for the best driver for your device. [Recommended]**, then click **Next**.
4. Select **Specify a location**, then click **Browse**.
5. Specify the folder containing the USB driver, **CD-ROM Drive:\USB driver\Win98**, then click **OK**.
6. Click **Next**.
7. Click **Next**.
8. Click **Finish**.

Note

If a dialog box appears asking you to restart your PC, restart the PC.

Windows Me

1. Connect the PC to the PBX with a USB cable.
The **Add New Hardware Wizard** will appear.
2. Select **Specify the location of the driver [Advanced]**, then click **Next**.
3. Select **Search for the best driver for your device. [Recommended]**.
4. Select **Specify a location**, then click **Browse**.
5. Specify the folder containing the USB driver, **CD-ROM Drive:\USB driver\WinMe**, then click **OK**.
6. Click **Next**.
7. Click **Next**.
8. Click **Finish**.

Note

If a dialog box appears asking you to restart your PC, restart the PC.

Windows 2000

1. Connect the PC to the PBX with a USB cable.
The **Found New Hardware Wizard** will appear.
2. Click **Next**.
3. Select **Search for a suitable driver for my device. [Recommended]**, then click **Next**.
4. Select **Specify a location**, then click **Next**.
5. Click **Browse**, and specify the folder containing the USB driver, **CD-ROM Drive:\USB driver\Win2000**, then click **Open**.
6. Click **OK**.
7. Click **Next**.
8. Click **Finish**.

Windows XP

1. Connect the PC to the PBX with a USB cable.
The **Found New Hardware Wizard** will appear.
2. Select **Install from a list or specific location [Advanced]**, then click **Next**.
3. Select **Search for the best driver in these locations**.
4. Select **Include this location in the search:**, then click **Browse**.
5. Specify the folder containing the USB driver, **CD-ROM Drive:\USB driver\WinXP**, then click **OK**.
6. Click **Next**.
7. Click **Continue Anyway**.
8. Click **Finish**.

3.2.2 Starting KX-TEA308 Maintenance Console for the first time

When you start the KX-TEA308 Maintenance Console with the Installer Level Programmer Code and connect to the PBX for the first time after initialisation (with factory default setting), Quick Setup will launch automatically. During Quick Setup, you will setup:

- The country code of the PBX. (This setting is only available when the model code is set to "CE" or "NE", and the country codes of the PBX and Maintenance Console do not match.)
- The date and time. The PBX uses the date and time set to the PC.
- The System Password.
- The operator extension number.
- Automatic Configuration for CO Line Type (DTMF [Dual Tone Multi-Frequency]/Pulse).
- The feature numbers for Operator Call and Automatic Line Access.
- Extension numbers and names.
- The Numbering Plan type.
- Ringing assignment for each outside (CO) line (either all extensions, or a specific extension).

Note

The screenshots shown here are for reference only, and may differ from the screens displayed on your PC.

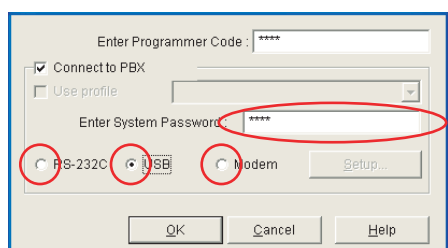

1. Start the KX-TEA308 Maintenance Console software from the start menu. (**Start** → **Programs** → **KX-TEA308 Maintenance Console**)
2. Type the Installer Level Programmer Code that was set during the KX-TEA308 Maintenance Console installation.
3.
 - a. Click the check box to connect to the PBX. Options will appear as shown here, on the left.
 - b. Type the System Password. (default: **1234**)
 - c. Select the method of connection.
 - d. Click **OK** to log in.
4. Quick Setup starts. Follow the on-screen instructions and assign the items as prompted.

Note

Software features, design, and system requirements are subject to change.

3.2.3 Accessing PBX via Internal Modem

1. Start the KX-TEA308 Maintenance Console software from the start menu on your PC. (**Start** → **Programs** → **KX-TEA308 Maintenance Console**)
2. Type the Installer Level Programmer Code that was set during the KX-TEA308 Maintenance Console installation.
3. Click the check box to connect to the PBX. Options will appear as shown here, on the left.
4. Type the System Password. (default: 1234)
5. Select **Modem**, and click **Setup**.

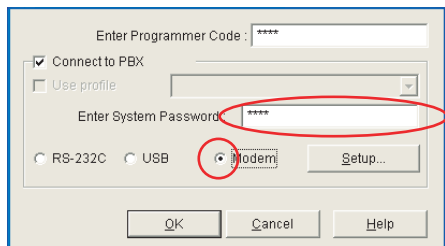
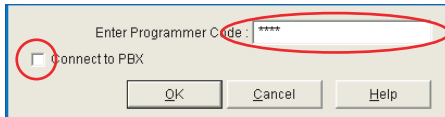

When the mode of the PBX outside (CO) line that will be accessed is 'MODEM':

1. For Dial Number, enter the telephone number assigned to the internal modem of the PBX.
2. Select **Auto (Tone)** or **Auto (Pulse)** for Dial Type.
3. Click **OK**.
4. Click **OK**. The PC will connect to the PBX.

When the mode of the PBX outside (CO) line that will be accessed is 'DISA':

1. For Dial Number, enter the telephone number assigned to the internal modem of the PBX, several pause symbols (',') and the Remote Maintenance feature number (for example: 01234567,,,,,729).
2. Select **Auto (Tone)** for Dial Type.
3. Click **OK**.
4. Click **OK**. The PC will connect to the PBX.

Notes

- The number of pause symbols to be inserted differs depending on the PC modem used.
- Auto (Pulse) Dial Type cannot be used.

When the mode of the PBX outside (CO) line that will be accessed is 'Normal':

1. For Dial Number, enter the pause symbol (',').
2. Select **Manual** for Dial Type.
3. Click **Initialise**.
4. Click **OK**.
5. Click **OK**.
6. Dial the telephone number assigned to the outside (CO) line from a telephone connected in parallel with the PC.
7. Ask the respondent to transfer the call to the internal modem of the PBX. ('Transfer' + '729 [Remote Maintenance feature number]')

8. Click **OK** and wait for 2 or 3 seconds, and then go on-hook before you hear a tone from the modem. The PC will connect to the PBX.

Notes

- The AT command 'Use V.22bis' may be required to configure the modem to communicate with the PBX, depending on the modem (for example: "AT + MS = V22B").
- The AT commands 'Use V.42' and 'Use V.42bis' may be required to configure the modem to communicate with the PBX, depending on the modem.
- The AT command to dial without waiting for a dial tone may be required to configure the modem to communicate with the PBX, depending on the modem.
- The AT command to set the Result Code format to text beginning with 'CONNECT' when a connection is established may be required to configure the modem to communicate with the PBX, depending on the modem.
- If the Baud Rate (bps) is set too high or too low the modem may not be able to communicate with the PBX, depending on the modem or PC. In this case, adjust the Baud Rate (bps) and reconnect to the PBX.

3.2 Connection

Section 4

Troubleshooting

This section provides information on troubleshooting and restarting the PBX.

4.1 Troubleshooting

4.1.1 Installation

PROBLEM	PROBABLE CAUSE	SOLUTION
<ul style="list-style-type: none"> Extension telephone does not function. 	<ul style="list-style-type: none"> Faulty connection between the PBX and telephone. Faulty telephone. A telephone with an A-A1 relay is connected. Faulty extension card. 	<ul style="list-style-type: none"> Plug the telephone into the same extension port using a short telephone cord. If the telephone functions, then the connection between the PBX and the telephone must be repaired. Plug the telephone into a known functioning extension port. If the telephone does not function, replace the telephone. Use a 2-wire cord. Set the A-A1 relay switch of the telephone to the "OUT" or "OFF" position. Exchange the card for a known functioning one.
<ul style="list-style-type: none"> Proprietary telephones (PTs) connected to extension jacks do not operate, but single line telephones (SLTs) do. 	<ul style="list-style-type: none"> The H and L pins of extension jacks may have shorted. 	<ul style="list-style-type: none"> Turn the Power Switch to the "OFF" position. Fix the shorted part, then turn the Power Switch to the "ON" position.
<ul style="list-style-type: none"> Noise heard through external pager (loudspeaker). 	<ul style="list-style-type: none"> If using an amplifier, noise may be being introduced through the cable connecting the PBX and the amplifier or loudspeaker. 	<ul style="list-style-type: none"> Use a shielded cable to connect the PBX and the amplifier or loudspeaker. A shorter cable will introduce less noise.
<ul style="list-style-type: none"> Audio (Music on Hold, Background Music) is distorted. 	<ul style="list-style-type: none"> Audio level from the output of the audio source is too high. 	<ul style="list-style-type: none"> Decrease the output level of the external audio source by using the volume control on the audio source.
<ul style="list-style-type: none"> Speed Dialling or One-touch Dialling does not function. 	<ul style="list-style-type: none"> Incorrect programming. 	<ul style="list-style-type: none"> Store the outside (CO) line access number (for example, 9 or 0, 81 through 83) at the beginning of the telephone number.
<ul style="list-style-type: none"> Improper operation other than the above. 		<ul style="list-style-type: none"> Turn the Power Switch to the "OFF" position, and then back to the "ON" position.

4.1.2 Connection

Telephone cord connecting the PBX and a proprietary telephone (PT):

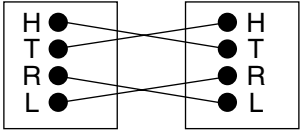
CAUSE	SOLUTION
<p>The T/R pins are connected to the H/L pins.</p>  <p>PBX Extension</p>	<p>Use the correct cord (the inner 2 wires are for T/R and the outer 2 wires are for H/L).</p>

Telephone cord connecting the PBX and a single line telephone (SLT):

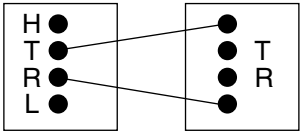
CAUSE	SOLUTION
<p>The T/R pins are connected to the H/L pins.</p>  <p>PBX Extension</p>	<p>Use the correct cord (the inner 2 wires are for T/R).</p>

Telephone cord connecting the PBX and an SLT that is polarity-sensitive:

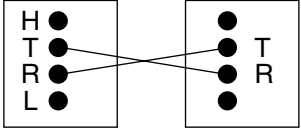
CAUSE	SOLUTION
<p>The T and R pins are crossed over.</p>  <p>PBX Extension</p>	<p>Reverse the connections of the T/R pins.</p>

Telephone cord connecting an outside (CO) line and the PBX:

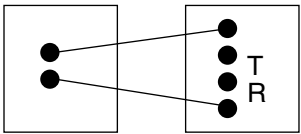
CAUSE	SOLUTION
<p>The outside (CO) line(s) is connected to the H/L pins.</p>  <p>Outside (CO) line PBX</p>	<p>Reconnect the outside (CO) line(s) to the T/R pins of the telephone jack using 2-conductor wiring.</p>

Can you dial an extension?

No

Yes

Can you dial out using an outside (CO) line?

No

4.1.3 Operation

PROBLEM	PROBABLE CAUSE	SOLUTION
<ul style="list-style-type: none"> When using the speakerphone on a proprietary telephone (PT), no sound is heard. 	<ul style="list-style-type: none"> The HANDSET/HEADSET selector is set to the "HEADSET" position. 	<ul style="list-style-type: none"> When the headset is not used, set the HANDSET/HEADSET selector to the "HANDSET" position.
<ul style="list-style-type: none"> The PT does not ring. 	<ul style="list-style-type: none"> The ringer volume is set to off. 	<ul style="list-style-type: none"> Set to "HIGH" or "LOW".
<ul style="list-style-type: none"> During a power failure, PTs connected to jack number 01 does not operate. 		<ul style="list-style-type: none"> Only single line telephones (SLTs) can be used during a power failure. Disconnect the PT and connect an SLT.
<ul style="list-style-type: none"> Outside (CO) line calls cannot be made with a PT. 	<ul style="list-style-type: none"> A flexible button on the PT has not been programmed to select an outside (CO) line. 	<ul style="list-style-type: none"> Programme the CO buttons. Refer to "1.18.2 Flexible Buttons" in the Feature Guide.
<ul style="list-style-type: none"> An SLT set to "tone" dialling mode cannot make calls. 	<ul style="list-style-type: none"> There may be something wrong with the DTMF (Dual Tone Multi-Frequency) receiver. 	<ol style="list-style-type: none"> Select "Enable" for DTMF receiver 1 and "Disable" for DTMF receiver 2 through system programming, "DTMF Receiver Check [107]". Try to make a call using a tone-type SLT connected to one of extension jacks 01–08. If you cannot make the call, the problem may have been caused by DTMF receiver 1. If the call can be made, go to step 4. Try DTMF receiver 2. Select "Disable" for DTMF receiver 1 and "Enable" for DTMF receiver 2 through system programming, "DTMF Receiver Check [107]", and make another call. If you cannot make the call, the problem may have been caused by DTMF receiver 2.

4.1.4 System Restart

If the PBX does not operate correctly, confirm that the operation/feature is being used correctly and refer to the Troubleshooting section if necessary. If the PBX still does not operate correctly, restart the PBX.

When the PBX is restarted:

- Calls on Hold are terminated.
- Calls on Exclusive Hold are terminated.
- Calls in progress are terminated.
- Automatic Callback Busy (Camp-on) is cleared.
- Call Park is cleared.
- Last Number Redial is cleared.
- Saved Number Redial is cleared.

No other data is cleared by System Restart.

1. To restart the PBX, turn the Power Switch to the "OFF" position, then turn the Power Switch back to the "ON" position.

Note

If the PBX still does not operate correctly, please see "4.1.5 System Reset with System Data Clear".

4.1.5 System Reset with System Data Clear

When the PBX does not operate correctly after restarting, you can clear the programming data stored in the PBX. The PBX will restart with the default settings.

1. Make sure that all outside (CO) lines you use are connected to the PBX.
2. Slide the System Clear Switch to the "CLR" position.
3. Press the Reset Button, and then return System Clear Switch to the "NOR" position before the power indicator stops flashing. (The power indicator will flash for about 5 seconds.)

CAUTION

Before touching the System Clear Switch and Reset Button, put on an earthing strap.

Notes

- After pressing the Reset Button, make sure to return the System Clear Switch to the "NOR" position before the power indicator stops flashing, otherwise the system data will not be cleared.
- The recorded outgoing messages (OGMs) for Direct Inward System Access (DISA), Uniform Call Distribution (UCD), and Built-in Voice Message (BV) are not cleared by the System Data Clear.

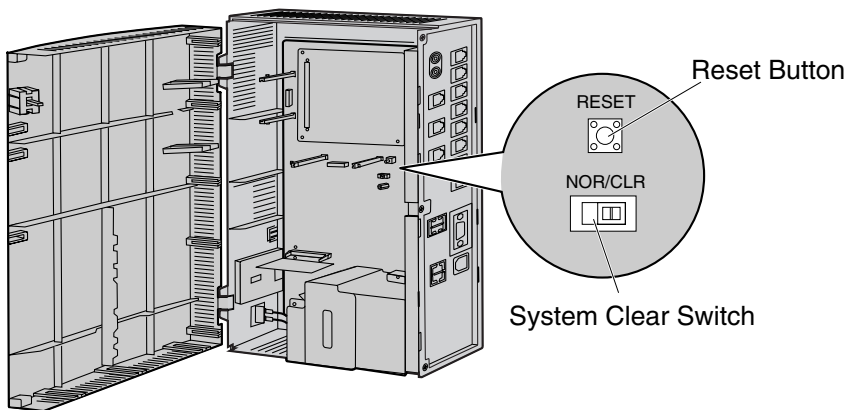

Section 5
Appendix

5.1 Revision History

5.1.1 Version 2.0

Changed Contents

- 2.3.4 2-Channel Voice Message Card (KX-TE82492)
- 2.10.1 Starting the Advanced Hybrid System

5.1.2 Version 3.0

New Options

- System Components Table
 - KX-TE82494 3-Port Caller ID Card

Index

Numerics

- 2-Channel Voice Message Card (KX-TE82492) 46
- 2-Port Doorphone Card (KX-TE82460) 45
- 3-Port Caller ID Card (KX-TE82494) 43

A

- About the Installation Manual 9
- About the Other Manuals 9
- Accessing PBX via Internal Modem 72
- Appendix 81

B

- Basic System Construction 17
- Before Installing 24

C

- Characteristics 20
- Connecting Backup Batteries 34
- Connecting Doorbell or Door Chime 56
- Connecting Doorphones and Door Openers 52
- Connecting Extensions 49
- Connecting Extensions in Parallel 51
- Connecting Frame Earth 33
- Connecting Outside (CO) Lines 48
- Connecting Peripherals 57
- Connection 68, 77

G

- General Description 19
- Guide for KX-TEA308 Maintenance Console 65

I

- Installation 23, 76
- Installation Precautions 24
- Installing KX-TEA308 Maintenance Console 67
- Installing KX-TEA308 Maintenance Console on a PC 66
- Installing Optional Service Cards 42
- Installing Surge Protector 39
- Installing the Advanced Hybrid System 26
- Installing the USB Driver 68

L

- Location of Optional Service Cards 42

M

- Main Unit 17
- Maximum Cabling Distance of Extension Wiring (Twisted Cable) 50
- Maximum Cards and Terminal Equipment 21
- Mounting on a Concrete or Mortar Wall 37
- Mounting on a Wooden Wall 36

N

- Names and Locations 27

O

- Opening/Closing Covers 28

- Operation 78

P

- Power Failure Connections 61

R

- Removing/Attaching the Front Cover 29
- Revision History 82

S

- Safety Installation Instructions 24
- Securing the Cables 31
- Serial Interface Connection 68
- Setting the Password and Password Security 66
- Specifications 19
- Starting KX-TEA308 Maintenance Console for the first time 71
- Starting the Advanced Hybrid System 62
- System Capacity 21
- System Components Table 2
- System Connection Diagram 18
- System Data 21
- System Highlights 16
- System Outline 15
- System Requirements 66
- System Reset with System Data Clear 80
- System Restart 79

T

- Troubleshooting 75

U

- Unpacking 26

V

- Version 2.0 82
- Version 3.0 82

W

- Wall Mounting 36
- Wiring Precautions 24

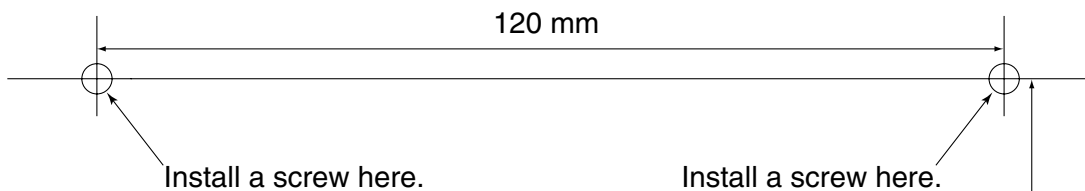

TEMPLATE FOR WALL MOUNTING

1. Copy or print this template and place it on the wall.
2. Install the screws as marked.
If you mount the main unit on a concrete or mortar wall, fit anchor plugs (not included) into the wall beforehand.
3. Hook the unit onto the screw heads.

Note

Make sure to set the print size to correspond with the size of this page. If the dimensions of the paper output still deviate slightly from the measurements indicated here, use the measurements indicated here.

232 mm

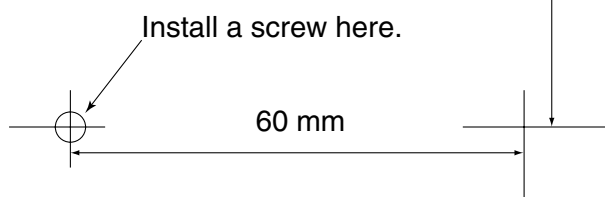

Panasonic System Networks Co., Ltd.

1-62, 4-chome, Minoshima, Hakata-ku, Fukuoka 812-8531, Japan

Copyright:

This material is copyrighted by Panasonic System Networks Co., Ltd., and may be reproduced for internal use only. All other reproduction, in whole or in part, is prohibited without the written consent of Panasonic System Networks Co., Ltd.

© Panasonic System Networks Co., Ltd. 2005